USER MANUAL / COMMAND REFERENCE

DMC-21x3

Amplifiers & Accessories

Manual Rev. 1.0k

*Galil Motion Control, Inc.
3750 Atherton Road
Rocklin, California 95765
Phone: (916) 626-0101
Fax: (916) 626-0102
Internet Address: support@galilmc.com
URL: www.galilmc.com*

Rev 12/06

Using This Manual

This user manual provides information for proper operation of the daughter boards that connect to the DMC-21x3 controllers. It also includes a small listing of commands that pertain to the daughter boards. This is a subset of the commands listed in the command reference you received with your motion controller.

Please note that many examples are written for the DMC-2143 four-axes controller or the DMC-2183 eight axes controller. Users of the DMC-2133 3-axis controller, DMC-2123 2-axes controller or DMC-2113 1-axis controller should note that the DMC-2133 uses the axes denoted as XYZ, the DMC-2123 uses the axes denoted as XY, and the DMC-2113 uses the X-axis only.

Examples for the DMC-2183 denote the axes as A,B,C,D,E,F,G,H. Users of the DMC-2153 5-axes controller denotes the axes as A,B,C,D,E. DMC-2163 6-axes controller denotes the axes as A,B,C,D,E,F. DMC-2173, 7-axes controller denotes the axes as A,B,C,D,E,F,G. In other words, the axes names A,B,C,D may be used interchangeably with X, Y, Z, W.

<p>WARNING: Machinery in motion can be dangerous! It is the responsibility of the user to design effective error handling and safety protection as part of the machine. Galil shall not be liable or responsible for any incidental or consequential damages.</p>
--

Contents

CONTENTS	1
CHAPTER 1 OVERVIEW	6
INTRODUCTION	6
DC TO DC OPTION	6
PINOUT	6
DC TO DC PASS THROUGH.....	6
MODULE TYPES	7
<i>Servo Drives</i>	7
<i>Stepper Drives</i>	7
<i>Non Amplifier Modules</i>	7
<i>Cables</i>	7
CHAPTER 2 SR-19900	8
INTRODUCTION	8
LAYOUT.....	9
PINOUT	9
CONFIGURATION.....	9
CHAPTER 3 ICM-20100	10
INTRODUCTION	10
LAYOUT.....	11
PINOUT	12
AMPLIFIER ENABLE	14
CHAPTER 4 ICM-20105	16
INTRODUCTION	16
ELECTRICAL SPECIFICATIONS.....	16
LAYOUT.....	17
PINOUT	18
CONFIGURATIONS FOR ICM-20105	20
<i>Amplifier Enable Circuit</i>	20
<i>Opto Isolation Settings</i>	22
CHAPTER 5 SDM-20240/20242.....	24
INTRODUCTION	24
ELECTRICAL SPECIFICATIONS.....	24
LAYOUT.....	25
PINOUT	26
<i>Mating Connectors</i>	28
CONFIGURATIONS FOR SDM-20240 & SDM-20242.....	28
<i>Motor Current Setting</i>	28
<i>Low Current Setting (JPI)</i>	29
ADDITIONAL SETTINGS FOR SDM-20242	30
<i>Protection Circuitry and Error LED</i>	30
<i>ELO (Emergency Lock Out)</i>	30
<i>Fault Output from SDM-20242</i>	30
CHAPTER 6 AMP-20341	32
INTRODUCTION	32

ELECTRICAL SPECIFICATIONS.....	32
LAYOUT.....	33
PINOUT	34
<i>Mating Connectors</i>	35
CHAPTER 7 AMP-20440/20420	36
INTRODUCTION	36
ELECTRICAL SPECIFICATIONS.....	36
LAYOUT.....	37
PINOUT	38
OVER-VOLTAGE PROTECTION	40
OVER-CURRENT PROTECTION	40
ABORT INPUT OPTIONS.....	41
CHAPTER 8 ICM-20500	42
INTRODUCTION	42
ELECTRICAL SPECIFICATIONS.....	43
LAYOUT.....	43
PINOUT	44
CONFIGURATION.....	45
CHAPTER 9 AMP-20540/20520	46
INTRODUCTION	46
ELECTRICAL SPECIFICATIONS.....	47
LAYOUT.....	47
PINOUT	48
<i>Mating Connectors</i>	50
OPERATION.....	51
<i>Brushless Motor Setup</i>	51
<i>Brushless Amplifier Software Setup</i>	51
<i>Brush Amplifier Operation</i>	52
<i>Using External Amplifiers</i>	52
<i>Error Monitoring and Protection</i>	53
<i>Hall Error Protection</i>	53
<i>Under-Voltage Protection</i>	54
<i>Over-Voltage Protection</i>	54
<i>Over-Current Protection</i>	54
<i>Over-Temperature Protection</i>	54
ABORT INPUT OPTIONS.....	55
CHAPTER 10 AMP-20542	56
INTRODUCTION	56
ELECTRICAL SPECIFICATIONS.....	57
LAYOUT.....	57
PINOUT	58
<i>Mating Connectors</i>	60
OPERATION.....	61
<i>Brushless Motor Setup</i>	61
<i>Brushless Amplifier Software Setup</i>	61
<i>Brush Amplifier Operation</i>	62
<i>Using External Amplifiers</i>	62
<i>Error Monitoring and Protection</i>	62
<i>Hall Error Protection</i>	63
<i>Under-Voltage Protection</i>	63
<i>Over-Voltage Protection</i>	63
<i>Over-Current Protection</i>	63

ABORT INPUT OPTIONS.....	63
CHAPTER 11 SDM-20640/20620.....	64
INTRODUCTION.....	64
ELECTRICAL SPECIFICATIONS.....	64
LAYOUT.....	65
PINOUT.....	65
<i>Mating Connectors</i>	67
CONFIGURATIONS FOR SDM-206x0.....	68
<i>Current Level Setup (AG Command)</i>	68
<i>Low Current Setting (LC Command)</i>	68
ABORT INPUT OPTIONS.....	68
CHAPTER 12 PCM-20900.....	70
INTRODUCTION.....	70
CHAPTER 13 DB-28040.....	72
INTRODUCTION.....	72
ELECTRICAL SPECIFICATIONS.....	72
LAYOUT.....	73
PINOUT.....	74
INTERFACING TO THE DIGITAL I/O.....	75
16 BIT ANALOG INPUTS.....	75
SSI.....	75
DB-28040 AND AMP-205x0.....	75
DB-28040 AND AMP-205x2 OR SDM-20640.....	76
CHAPTER 14 DB-28104.....	78
INTRODUCTION.....	78
THEORY OF OPERATION.....	79
SETTING UP THE ENCODER.....	81
TUNING THE SYSTEM.....	83
EXAMPLE SIN/COS ENCODERS.....	85
APPENDIX A- DB-28104 DIMENSIONS.....	86
CHAPTER 15 CABLES FOR AMP-205X0, 20542 AND 204X0.....	88
APPENDIX A ABORT INPUT OPTIONS.....	94
ELO SCENARIOS.....	94
<i>DMC-2143 with AMP-20540</i>	94
<i>DMC-2143 with SDM-20640</i>	94
<i>DMC-2183 with two AMP-20440s</i>	95
APPENDIX B MATING D-SHELLS.....	96
APPENDIX C COMMAND REFERENCE.....	98
<i>AE</i>	99
<i>AG</i>	100
<i>AU</i>	101
<i>AW</i>	102
<i>BR</i>	103
<i>BS</i>	104
<i>CN</i>	105
<i>CO</i>	106
<i>LC</i>	107
<i>QH</i>	108
<i>TA</i>	109

<i>TK</i>	<i>110</i>
<i>TL (Binary 8a)</i>	<i>111</i>

THIS PAGE LEFT BLANK INTENTIONALLY

Chapter 1 Overview

Introduction

Galil's DMC-21x3 series motion controllers connect with daughterboard modules that mount directly on the motion controller. This eliminates the need for a separate cable between the motion controller and the amplifier or breakout module. This approach saves the cost of the cable and significantly reduces the real estate required for the controls within a system.

The DMC-21x3 uses a rugged 96 pin DIN board-to-board connector to interface the daughter boards with the motion controller. The same controller can be ordered with different modules for different system requirements. This controller series supports modules ranging from passive breakout modules to 500W-per-channel brush and brushless servo drives to stepper and microstepper drives. Each module breaks out the I/O provided by the controller and some of the boards also provide additional I/O functions such as analog inputs or optoisolation. If you do not find the exact module you are looking for, please contact Galil at 800-377-6329. We will work closely with you to create a module that will fit your needs.

DC to DC Option

The DMC-21x3 series controllers can be ordered with an optional DC-to-DC converter so that a single DC power supply can be used to power the controller (as opposed to the standard 5 V and +/-12 V input). This can be ordered as either the -DC24 (18-36 VDC range) or -DC48 (36-72 VDC range). With the DC option, a 4-pin molex power connector is provided for DC supply to controller at J99.

Pinout

J99 4-Pin Molex	
1	Earth (optional)
2	No connection
3	V _{in} (18-36 or 36-72 VDC)
4	GND

Mating connector = AMP #770 849-4

Pins = AMP #770 476-1

DC to DC Pass Through

When using the DC-to-DC converter in conjunction with the Galil amplifier daughter boards described in this manual, there is an option to have the DC power supply input shared among both boards, which alleviates the need to supply power to two connectors. Power is passed through from the amp to the controller via the "Pass Through" header located at J98 (1-4 axes) or JP14 (5-8 axes) on the controller.

When using the pass through on a 1-4 axis DMC-21x3 controller, DC power must be applied only to the amplifier's power connector.

When using the pass through on a 5-8 axis DMC-21x3 controller, DC power must be applied to both amplifier's power connectors. Power is passed through to the controller only from the second (axes E-H) amplifier

The proper DC-to-DC converter must be chosen so that the DC voltage range is compatible with the amplifier and motor voltage requirements. The J98/JP14 header comes standard, hence the purchaser must specify if they would not like this header present with –NOJ98.

Module Types

Servo Drives

Part Number	Description
AMP-20340	4 Axis Brush Type 20 Watt Linear Servo Drives. OBSOLETE
AMP-20341	4 Axis Brush Type 20 Watt Linear Servo Drives (bipolar supply)
AMP-20420	2 Axis Brush Type 200 Watt/Axis PWM Servo Drives
AMP-20440	4 Axis Brush Type 200 Watt/Axis PWM Servo Drives
AMP-20520	2 Axis Brushless/Brush 500 Watt/Axis PWM Servo Drives
AMP-20540	4 Axis Brushless/Brush 500 Watt/Axis PWM Servo Drives

Stepper Drives

Part Number	Description
SDM-20240	4 Axis 2 Phase Full/Half Step Stepper Motor Drive
SDM-20620	2 Axis 2 Phase Micro Stepper Motor Drive
SDM-20640	4 Axis 2 Phase Micro Stepper Motor Drive

Non Amplifier Modules

Part Number	Description
ICM-20100	4 Axis Breakout to D Shell Connectors
ICM-20105	4 Axis Breakout to D Shell Connectors with opto-isolated I/O
DB-28040	Additional Configurable I/O and 8 Dedicated Analog Inputs
DB-28104	Accepts Sin/Cos Encoder Feedback
PCM-20900	Breadboard Module to Aid Design of Customer Daughter Boards
SR-19900	Shunt Regulator

Cables

Part Number	Description
CABLE-15-1m	15-pin high density D-sub cable with 1 m flying leads (AMP-204x0 and AMP-205x0)
CABLE-44-1m	44-pin high density D-sub cable with 1 m flying leads (AMP-204x0 and AMP-205x0)

Chapter 2 SR-19900

Introduction

For applications requiring a shunt regulator, Galil offers a small mountable model that can be configured for varying voltage levels. Two fixed voltage threshold settings are available with jumpers, which can be set at either 33 or 66 volts. Additionally, a user defined voltage threshold can be set by changing a simple resistor. This shunt regulator operates with hysteresis, where the regulator switches on at the set voltage threshold and switches off at 2 volts below.

The shunt regulator should be placed in parallel with the power supply as in the figure below, and it should be mounted to a metal surface using thermal grease to aid in heat transfer. Connections are made to the unit at VS (voltage supply) and PG (power ground) using either the 4-pin Molex connector or the 8-pin Mate 'N Lock connector (AMP# 770579-1).

For a summary of shunt regulator operation, as well as details to help determine if one is required in your system, please refer to application note #5448 at: (<http://www.galilmc.com/support/appnotes/miscellaneous/note5448.pdf>).

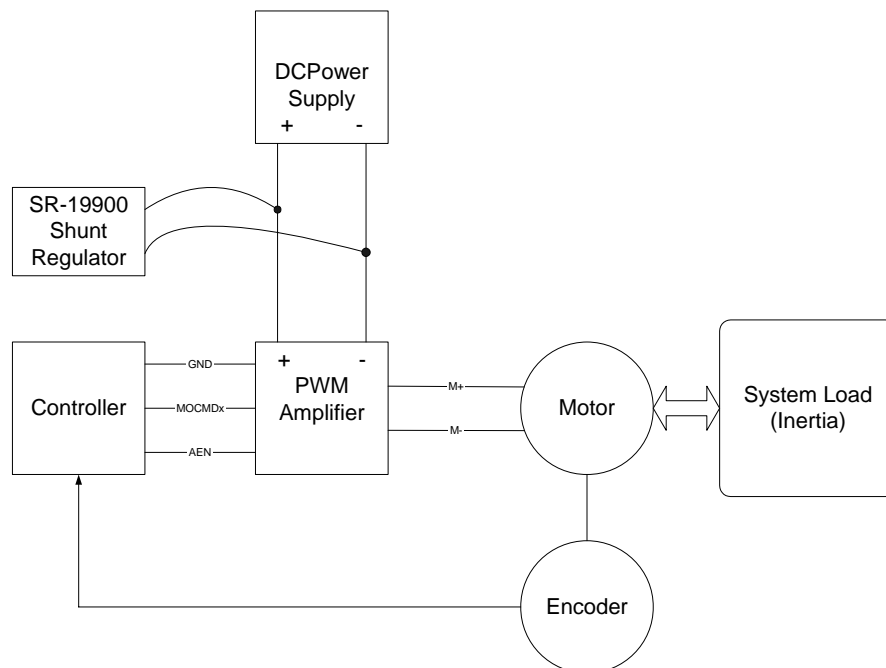

Figure 1 Shunt Regulator Placement in a Typical Servo System

Layout

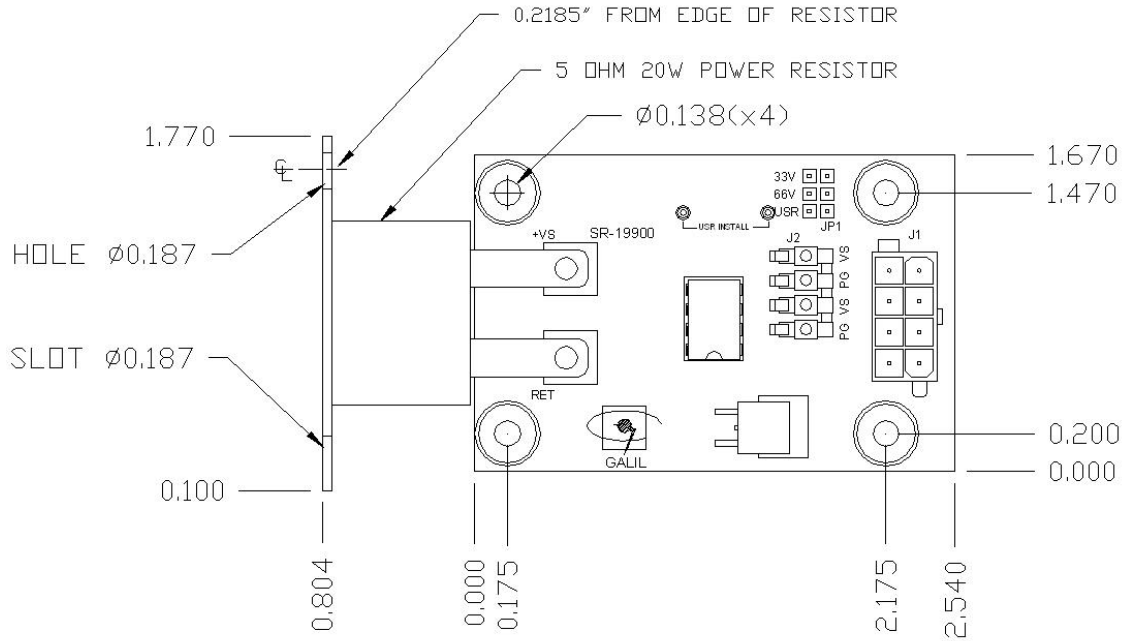

Figure 2 SR-1990 Layout

Pinout

	J2 4-pin Molex
Power Ground	1 PG
Voltage Supply	2 VS
Power Ground	3 PG
Voltage Supply	4 VS

J1 8-pin Mate 'N Lock	
1 Earth	5 PG
2 VS	6 PG
3 VS	7 PG
4 VS	8 PG

Configuration

SR-1990 Configuration	
Voltage Threshold Setting (Vs)	JP1
33 volts	33V
66 volts	66V
User selectable	USR

USR - User Settable Voltage	
$R8 = 1930 * Vs - 42.2K$	
Voltage (Vs)	R8 value (ohms)
24	4.12 k
48	50.44 k
72	96.76 k

Chapter 3 ICM-20100

Introduction

The ICM-20100 interconnect module provides D-Sub connections between the DMC-21x3 series controllers and other system elements, such as amplifiers, encoders, and external switches. The ICM-20100 provides access to the signals for up to 4 axes (two required for 5 or more axes).

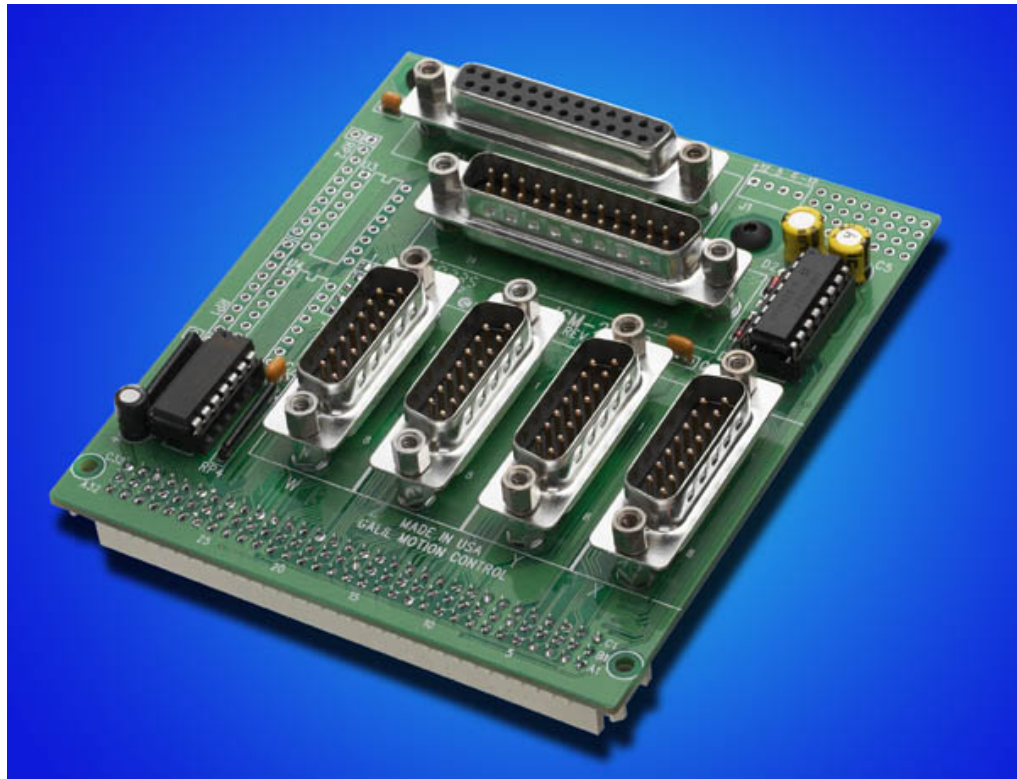
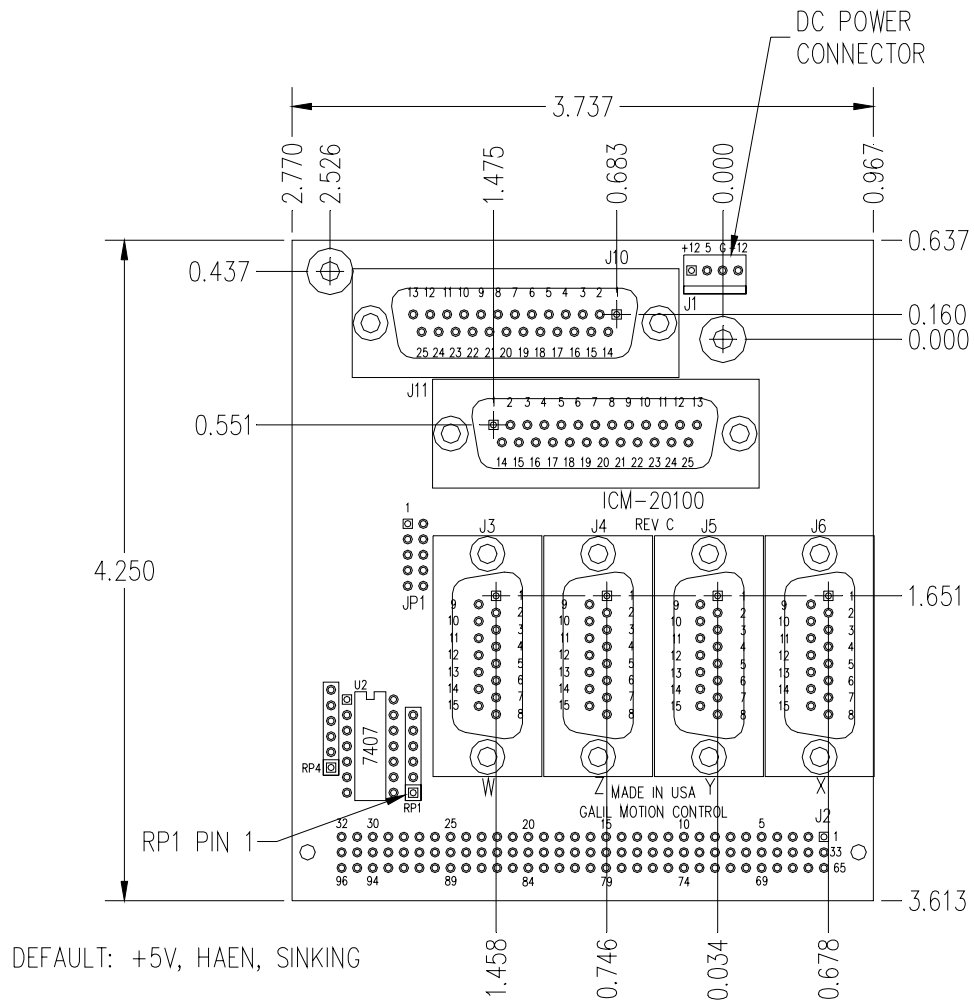

Figure 3 ICM-20100

Layout



Drawing Not to Scale. For Reference Only. Dimensions are inches

Figure 4 ICM-20100 Layout
 Board Dimensions are 3.7" x 4.25". See [Application Note #1231](#) for Hole Locations.

Pinout

J6	X-Axis 15-pin Male D-sub
1	Forward limit X
2	Home X
3	5V
4	A- X
5	B- X
6	I- X
7	Amp enable X
8	Sign/dir X
9	Reverse limit X
10	Ground
11	A+ X
12	B+ X
13	I+ X
14	Motor command X
15	PWM/step X

J5	Y-Axis 15-pin Male D-sub
1	Forward limit Y
2	Home Y
3	5V
4	A- Y
5	B- Y
6	I- Y
7	Amp enable Y
8	Sign/dir Y
9	Reverse limit Y
10	Ground
11	A+ Y
12	B+ Y
13	I+ Y
14	Motor command Y
15	PWM/step Y

J4	Z-Axis 15-pin Male D-sub
1	Forward Limit Z
2	Home Z
3	5V
4	A- Z
5	B- Z
6	I- Z
7	Amp enable Z
8	Sign/dir Z
9	Reverse limit Z
10	Ground
11	A+ Z
12	B+ Z
13	I+ Z
14	Motor command Z
15	PWM/step Z

J3	W-Axis 15-pin Male D-sub
1	Forward Limit W
2	Home W
3	5V
4	A- W
5	B- W
6	I- W
7	Amp enable W
8	Sign/dir W
9	Reverse limit W
10	Ground
11	A+ W
12	B+ W
13	I+ W
14	Motor command W
15	PWM/step W

J10	Aux Encoders 25-pin Female D-Sub
1	Reset *
2	AB- W
3	AA- W
4	AB- Z
5	AA- Z
6	AB- Y
7	AA- Y
8	AB- X
9	AA- X
10	5V
11	5V
12	+12V
13	NC
14	Error Output *
15	AB+ W
16	AA+ W
17	AB+ Z
18	AA+ Z
19	AB+ Y
20	AA+ Y
21	AB+ X
22	AA+ X
23	Ground
24	Ground
25	-12V

J11	I/O 25-pin Male D-Sub
1	Ground
2	Latch X/Input 1
3	Latch Z/Input 3
4	Input 5
5	Input 7
6	Abort *
7	Output 1
8	Output 3
9	Output 5
10	Output 7
11	Ground
12	NC
13	NC
14	5V
15	Latch Y/Input 2
16	Latch W/Input 4
17	Input 6
18	Input 8
19	Encoder-compare output
20	Output 2
21	Output 4
22	Output 6
23	Output 8
24	5V
25	NC
	* Active Low Signal

Amplifier Enable

The standard configuration of the AMPEN signal is TTL active high. In other words, the AMPEN signal will be high when the controller expects the amplifier to be enabled. The polarity and the amplitude can be changed. To change the polarity from active high (5 volts= enable, zero volts = disable) to active low (zero volts = enable, 5 volts= disable), replace the 7407 IC with a 7406 (U2). Note that many amplifiers designate the enable input as ‘inhibit’.

To change the voltage level of the AMPEN signal, note the state of the resistor pack on the ICM-20100. When pin 1 of the resistor matches pin 1 of the RP1, the output voltage is 0-5 V. To change to 12 volts, pull the resistor pack and rotate it so that pin 1 is on the 12 volt side. Pin 1 of the resistor will be marked with a designator, pin 1 of location RP1 can be determined by the square through hole on the circuit board denoting pin 1. If you remove the resistor pack, the output signal is open collector, allowing the user to connect an external supply with voltages up to 24V. Note that any external pull-up resistor should limit the current draw to 10 mA

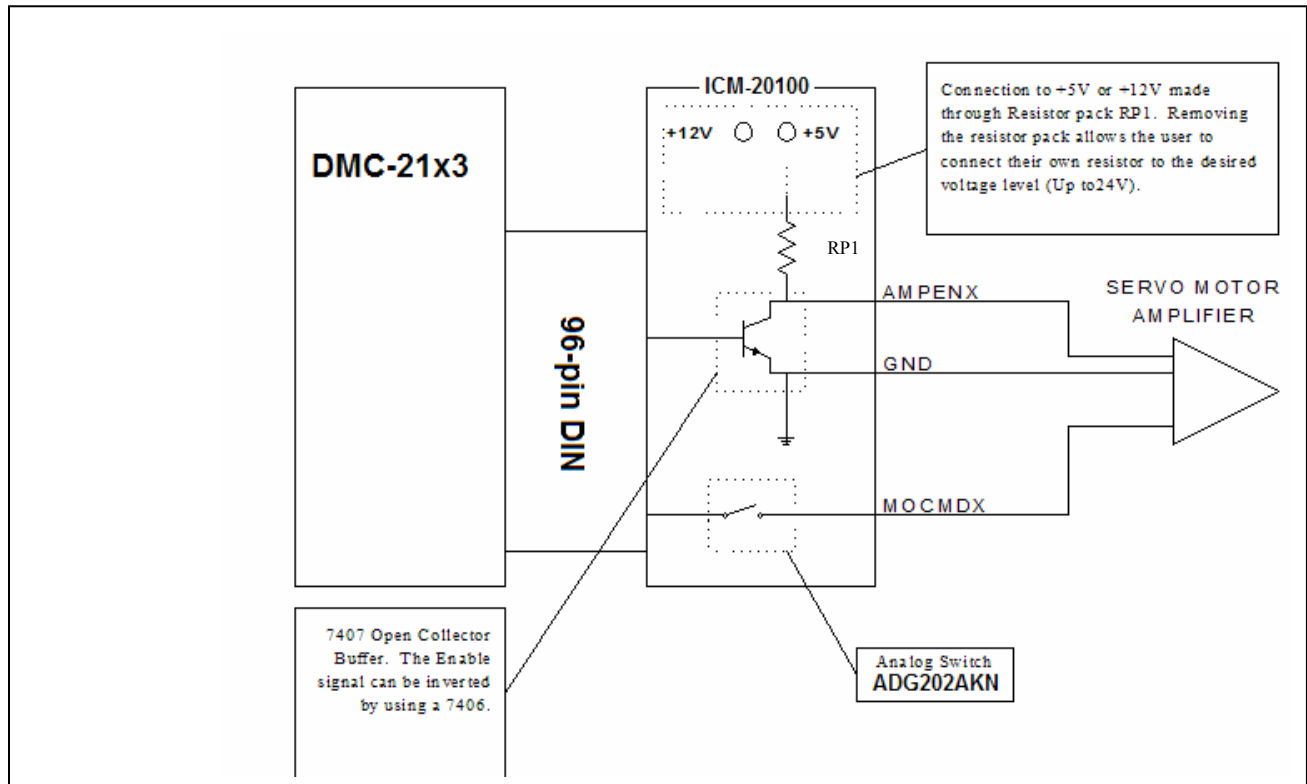

Figure 5 ICM-20100 Amplifier Enable Circuit

THIS PAGE LEFT BLANK INTENTIONALLY

Chapter 4 ICM-20105

Introduction

The ICM-20105 opto-isolated I/O module are used with DMC-21x3 controllers. It has four 15-pin Male D-Sub connectors for individual axis signals. There is one 37-pin D-Sub for the 8 digital inputs, 8 high side drive 500 mA digital outputs, home switches, limit switches, and one 25-pin D-Sub for 4 axes of auxiliary encoders.

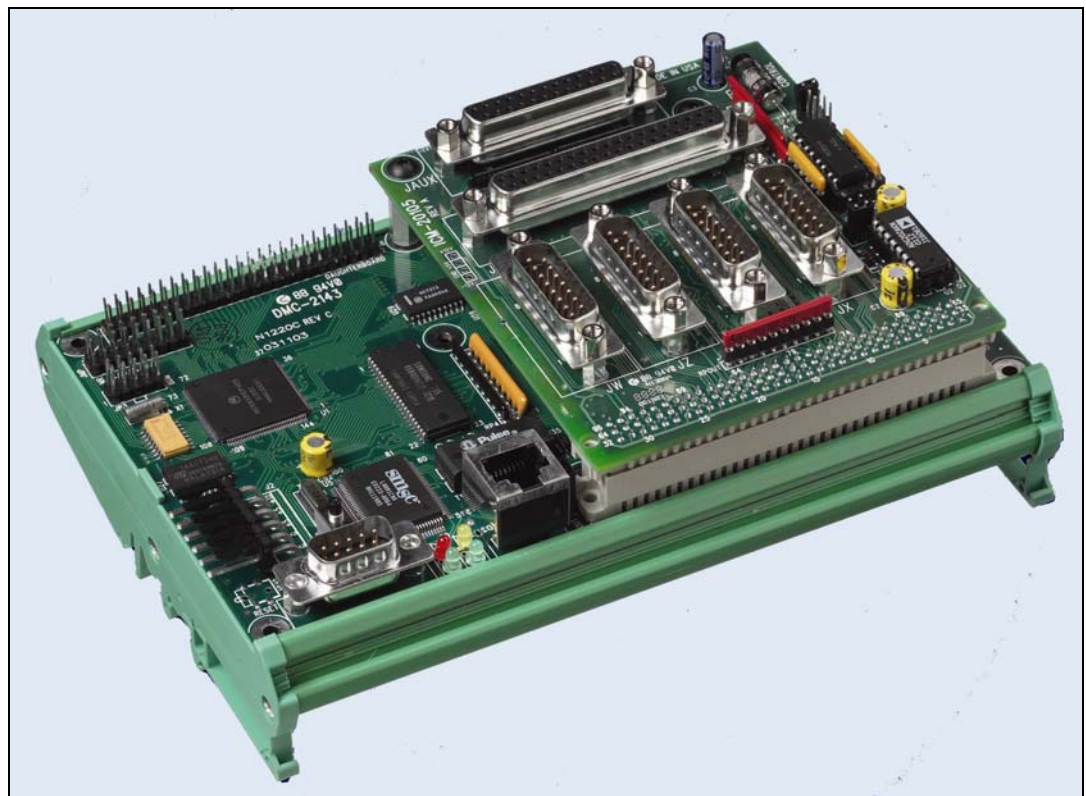

Figure 6 ICM-20105 shown mounted to a DMC-2143

Electrical Specifications

Input Common Max Voltage	28 VDC
Output Common Max Voltage	30 VDC
Max Drive Current per Output	0.5 A (not to exceed 3A for all 8 outputs)
Minimum Current to turn on Inputs	1 mA
Max Enable Current @24V	source 25 mA

Pinout

JX X-axis 15-Pin Male D-sub
1 Amp enable common-1 (AECOM1)
2 Amp enable X
3 5V
4 A- X
5 B- X
6 I- X
7 NC
8 Sign/dir X
9 Amp enable common-2 (AECOM2)
10 Ground
11 A+ X
12 B+ X
13 I+ X
14 Motor command X
15 PWM/step X

JY Y-axis 15-Pin Male D-sub
1 Amp enable common-1 (AECOM1)
2 Amp enable Y
3 5V
4 A- Y
5 B- Y
6 I- Y
7 NC
8 Sign/dir Y
9 Amp enable common-2 (AECOM2)
10 Ground
11 A+ Y
12 B+ Y
13 I+ Y
14 Motor Command Y
15 PWM/step Y

JZ Z-axis 15-Pin Male D-sub
1 Amp enable common-1 (AECOM1)
2 Amp enable Z
3 5V
4 A- Z
5 B- Z
6 I- Z
7 NC
8 Sign/dir Z
9 Amp enable common-2 (AECOM2)
10 Ground
11 A+ Z
12 B+ Z
13 I+ Z
14 Motor Command Z
15 PWM/step Z

JW W-axis 15-Pin Male D-sub
1 Amp enable common-1 (AECOM1)
2 Amp enable W
3 5V
4 A- W
5 B- W
6 I- W
7 NC
8 Sign/dir W
9 Amp enable common-2 (AECOM2)
10 Ground
11 A+ W
12 B+ W
13 I+ W
14 Motor Command W
15 PWM/step W

JAUX Aux. Encoder 25-pin Female D
1 NC
2 AB- W
3 AA- W
4 AB- Z
5 AA- Z
6 AB- Y
7 AA- Y
8 AB- X
9 AA- X
10 5V
11 5V
12 +12V
13 NC
14 NC
15 AB+ W
16 AA+ W
17 AB+ Z
18 AA+ Z
19 AB+ Y
20 AA+ Y
21 AB+ X
22 AA+ X
23 Ground
24 Ground
25 -12V

JIO I/O 37-Pin Female D-sub
1 Input Common Voltage
2 Input 2
3 Input 4
4 Input 6
5 Input 8
6 Output Supply Voltage
7 Output 2
8 Output 4
9 Output 6
10 Output 8
11 Limit Switch Common
12 Reverse Limit X
13 Forward Limit Y
14 Home Y
15 Reverse Limit Z
16 Forward Limit W
17 Home W
18 5V
19 Ground
20 Input 1
21 Input 3
22 Input 5
23 Input 7
24 Abort
25 Output 1
26 Output 3
27 Output 5
28 Output 7
29 Output Return
30 Forward Limit X
31 Home X
32 Reverse Limit Y
33 Forward Limit Z
34 Home Z
35 Reverse Limit W
36 5V
37 Ground

Configurations for ICM-20105

Amplifier Enable Circuit

The ICM-20105 gives the user a broad range of options with regards to the voltage levels present on the enable signal. The user can choose between High-Amp-Enable (HAEN), Low-Amp-Enable (LAEN), 5V logic, 12V logic, external voltage supplies up to 24V, sinking, or sourcing. The tables below illustrate the settings for jumpers, R Packs, and the socketed optocoupler IC. Refer to Figure 7 for precise physical locations of all components. Note that the resistor pack located at RPAE1 may be reversed to change the active state of the amplifier enable output. The polarity of RPAE2 must not be changed; however, a different resistor value may be needed to limit the current to 6 mA. The default value for RPAE2 is 820 ohms, which works at 5V. When using 24V, RPAE2 should be replaced with a 4.7 kΩ resistor pack.

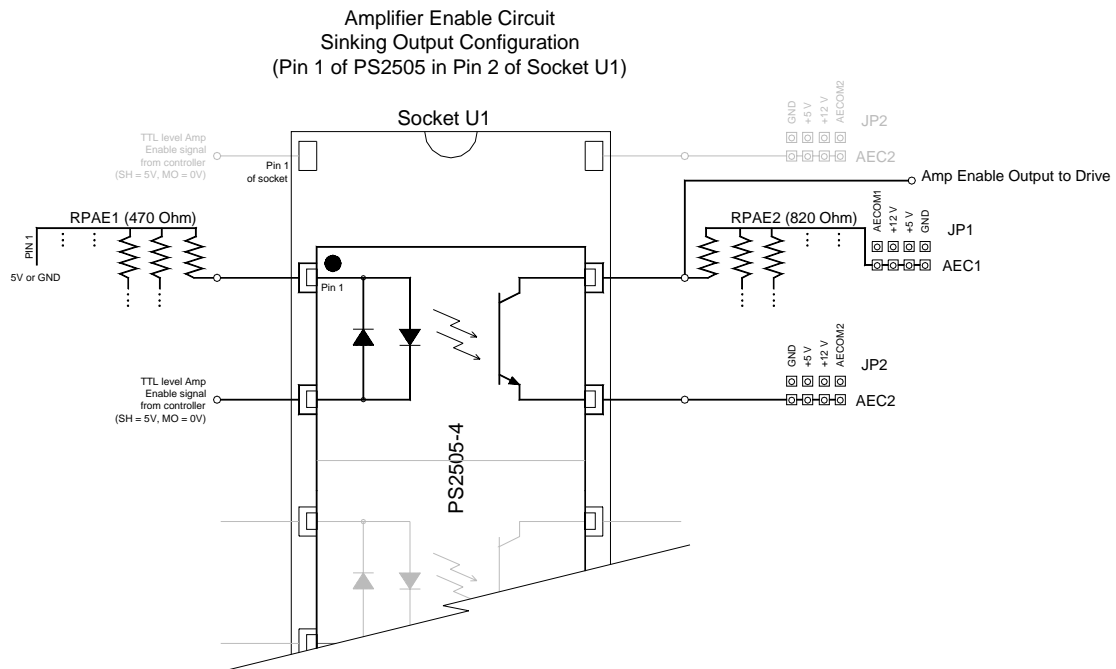

Figure 8 Amplifier Enable Circuit Output Configuration

Sinking Configuration (pin1 of PS2505 chip in pin2 of socket U1)			
Logic State	JP1	JP2	RPAE1 (square pin next to RPAE1 label is 5V)
5V, HAEN (Default Configuration)	5V - AEC1	GND - AEC2	Dot on R-pack next to RPAE1 label
5V, LAEN	5V - AEC1	GND - AEC2	Dot on R-pack opposite RPAE1 label
12V, HAEN	+12V - AEC1	GND - AEC2	Dot on R-pack next to RPAE1 label
12V, LAEN	+12V - AEC1	GND - AEC2	Dot on R-pack opposite RPAE1 label
Isolated 24V, HAEN	AECOM1 - AEC1	AECOM2 - AEC2	Dot on R-pack next to RPAE1 label
Isolated 24V, LAEN	AECOM1 - AEC1	AECOM2 - AEC2	Dot on R-pack opposite RPAE1 label

For 24V isolated enable, tie +24V of external power supply to AECOM1 at any axis D-sub, tie common return to AECOM2. Replace RPAE2 with a 4.7 kΩ resistor pack. AECOM1 and AECOM2 are located on any 15-pin axis D-sub (JX, JY, JZ, or JW). All pins labeled AECOM1 are connected. All pins Labeled AECOM2 are connected.

**Amplifier Enable Circuit
Sourcing Output Configuration
(Pin 1 of PS2505 in Pin 1 of Socket U1)**

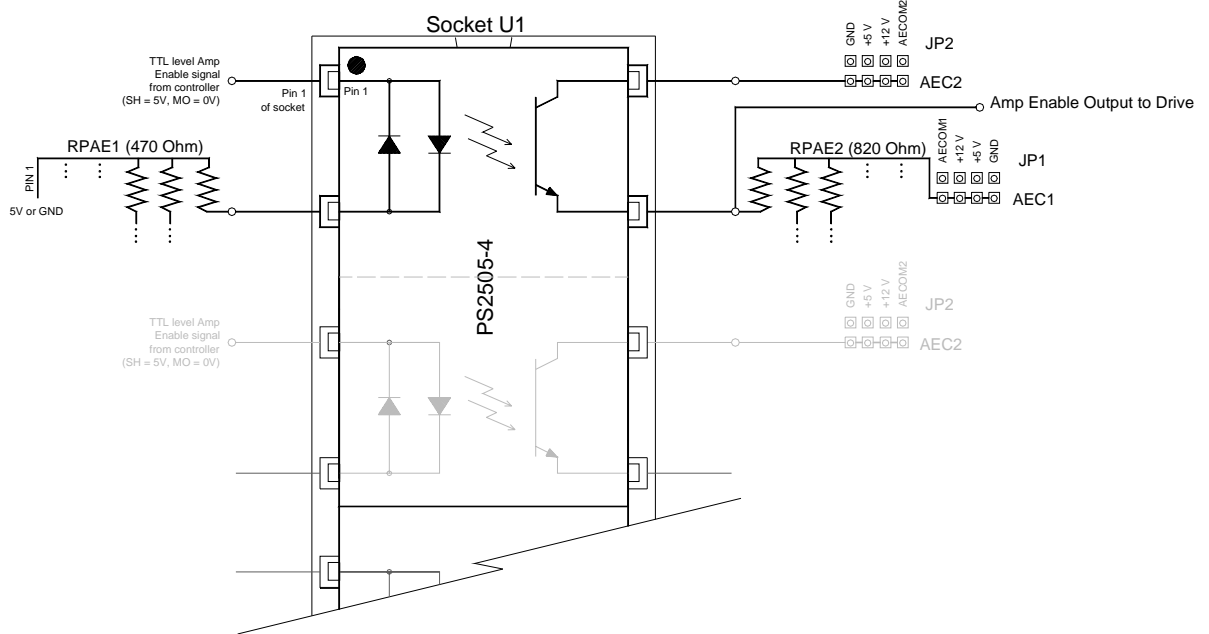

Figure 9 Amplifier Enable Circuit Sourcing Output Configuration

Sourcing Configuration (pin1 of PS2505 chip in pin1 of socket U1)

Logic State	JP1	JP2	RPAE1 (square pin next to RPAE1 label is 5V)
5V, HAEN	GND - AEC1	5V - AEC2	Dot on R-pack opposite RPAE1 label
5V, LAEN	GND - AEC1	5V - AEC2	Dot on R-pack next to RPAE1 label
12V, HAEN	GND - AEC1	+12V - AEC2	Dot on R-pack opposite RPAE1 label
12V, LAEN	GND - AEC1	+12V - AEC2	Dot on R-pack next to RPAE1 label
Isolated 24V, HAEN	AECOM1 - AEC1	AECOM2 - AEC2	Dot on R-pack opposite RPAE1 label
Isolated 24V, LAEN	AECOM1 - AEC1	AECOM2 - AEC2	Dot on R-pack next to RPAE1 label

For 24V isolated enable, tie +24V of external power supply to AECOM2 at any axis D-sub, tie common return to AECOM1. Replace RPAE2 with a 4.7 kΩ resistor pack. AECOM1 and AECOM2 are located on any 15-pin axis D-sub (JX, JY, JZ, or JW). All pins labeled AECOM1 are connected. All pins Labeled AECOM2 are connected.

Opto Isolation Settings

The ICM-20105 module allows for opto-isolation on all of the digital inputs and outputs. This includes the dedicated I/O including limits, homes, and abort. The limits and home are powered by Limit Switch Common. The digital inputs and the Abort Input are powered by Input Common. The digital outputs are also optically isolated and are capable of sourcing up to 0.5 A per pin with a 3 A limit for the group of 8 outputs. The outputs are configured for hi-side drive only. The supply voltage must be connected to *output supply voltage*, and the supply return must be connected to *output return*.

Input Isolation

Opto isolation of the general purpose inputs and the abort input is used by powering the Input Common line. The limit switch and home inputs are powered by Limit Switch Common. Shown below is the circuit diagram for the isolated inputs.

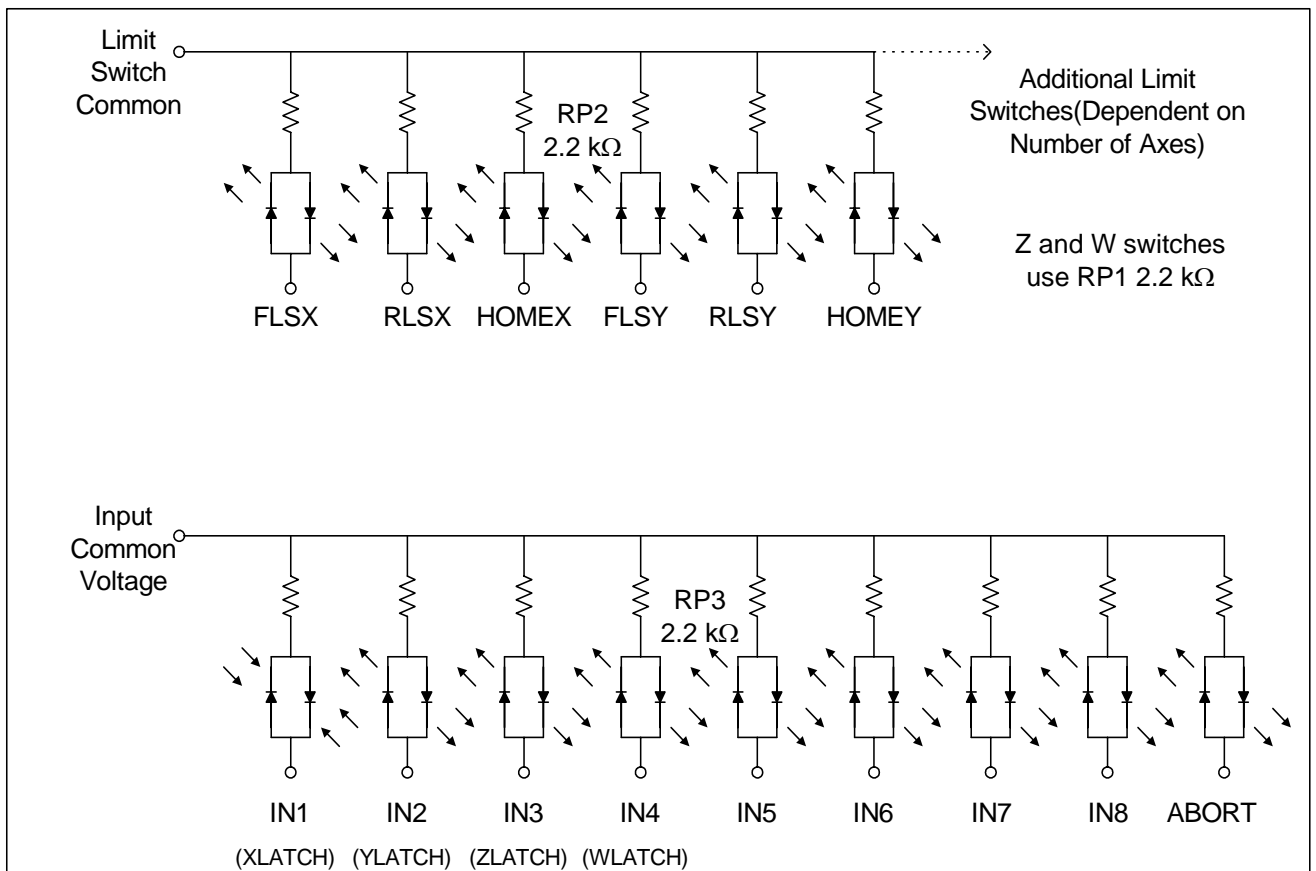

Figure 10 ICM-20105 Digital Input Isolation

Output Isolation

The high current isolated outputs available through the ICM-20105 are configured for High Side operation. The outputs are capable of 500 mA per output with a total of 3 A from the group of 8 outputs. The figure below shows the manner in which the load should be connected. The output will be at the voltage that is supplied to the OUTSUP pin. Up to 30 VDC may be supplied to OUTSUP.

The RPOUT resistor pack allows configuration of the active state of the outputs. For example when you issue the SB1 command, the polarity of the resistor will determine whether the output is turned on or off.

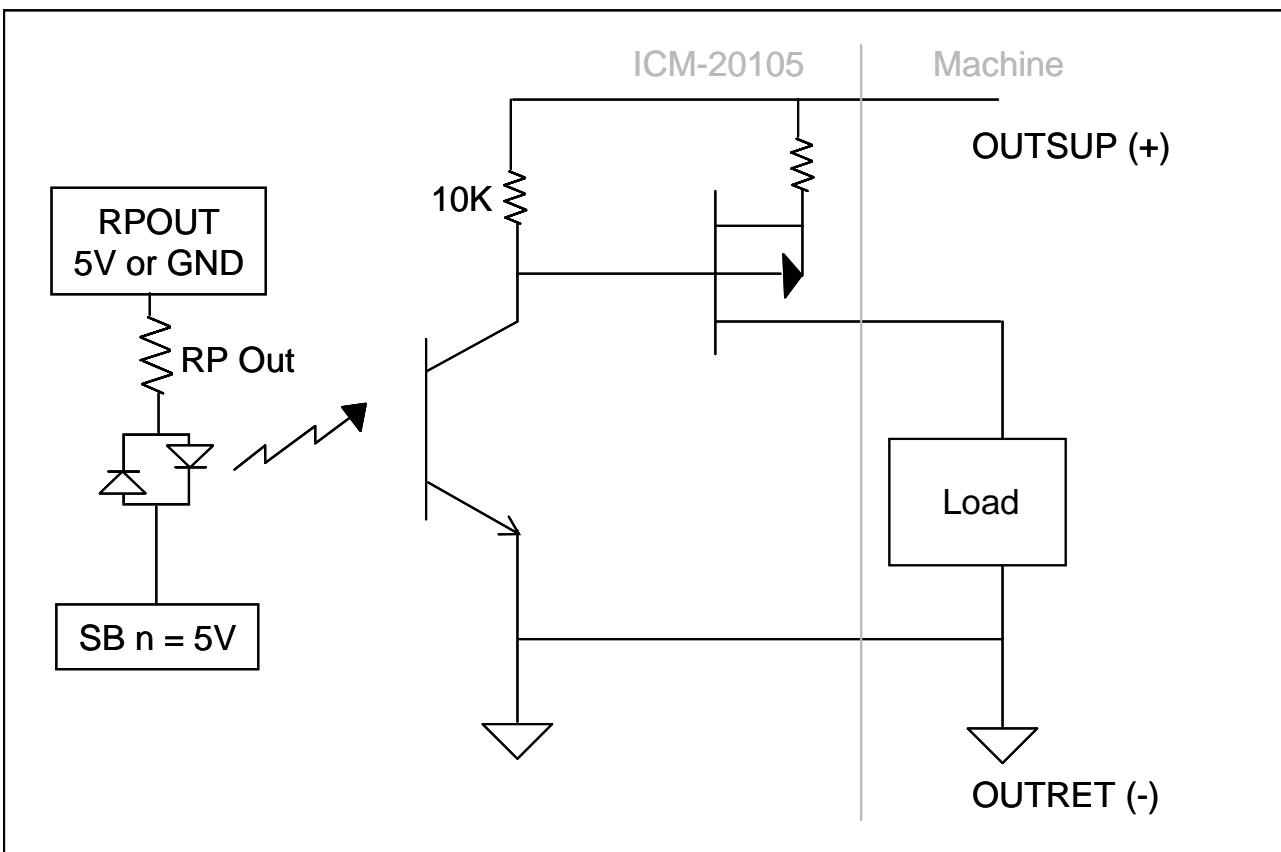

Figure 11 ICM-20105 General-Purpose Digital Output Opto-Isolation

Chapter 5 SDM-20240/20242

Introduction

The SDM-20240 and SDM-20242 are stepper driver modules capable of driving up to four bipolar two-phase stepper motors. The current is selectable with options of 0.5, 0.75, 1.0, and 1.4 Amps/Phase. **The SDM-20242 is the replacement for the SDM-20240 as of December 2006.**

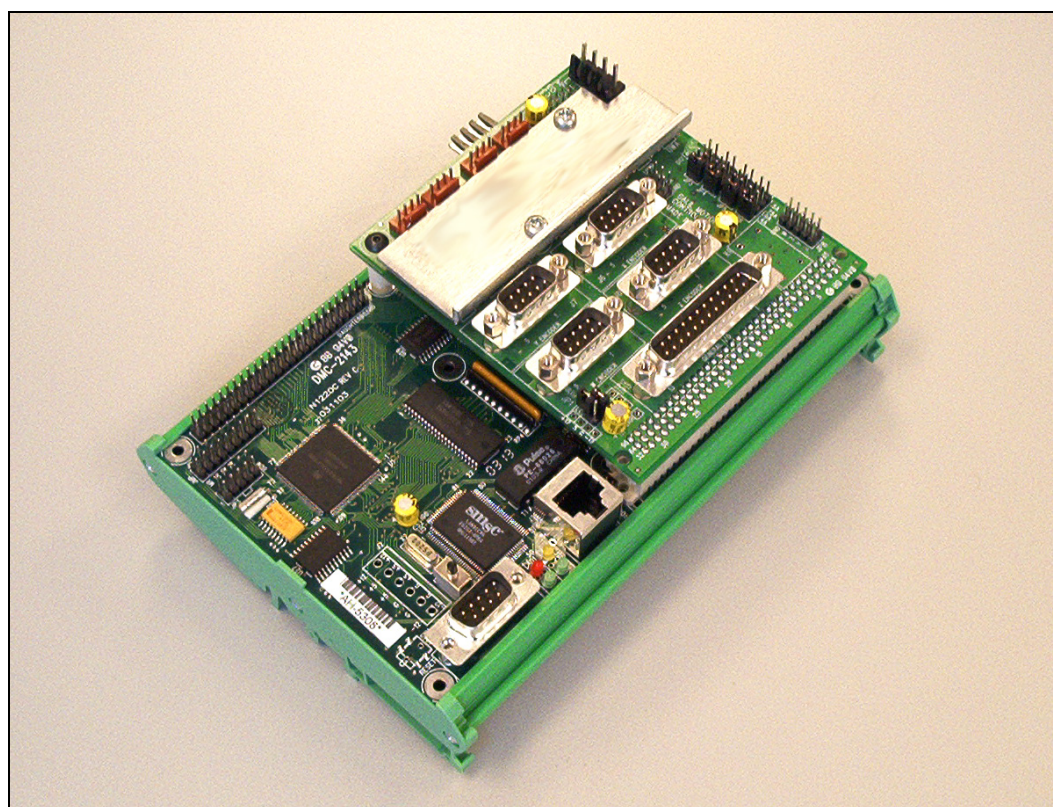
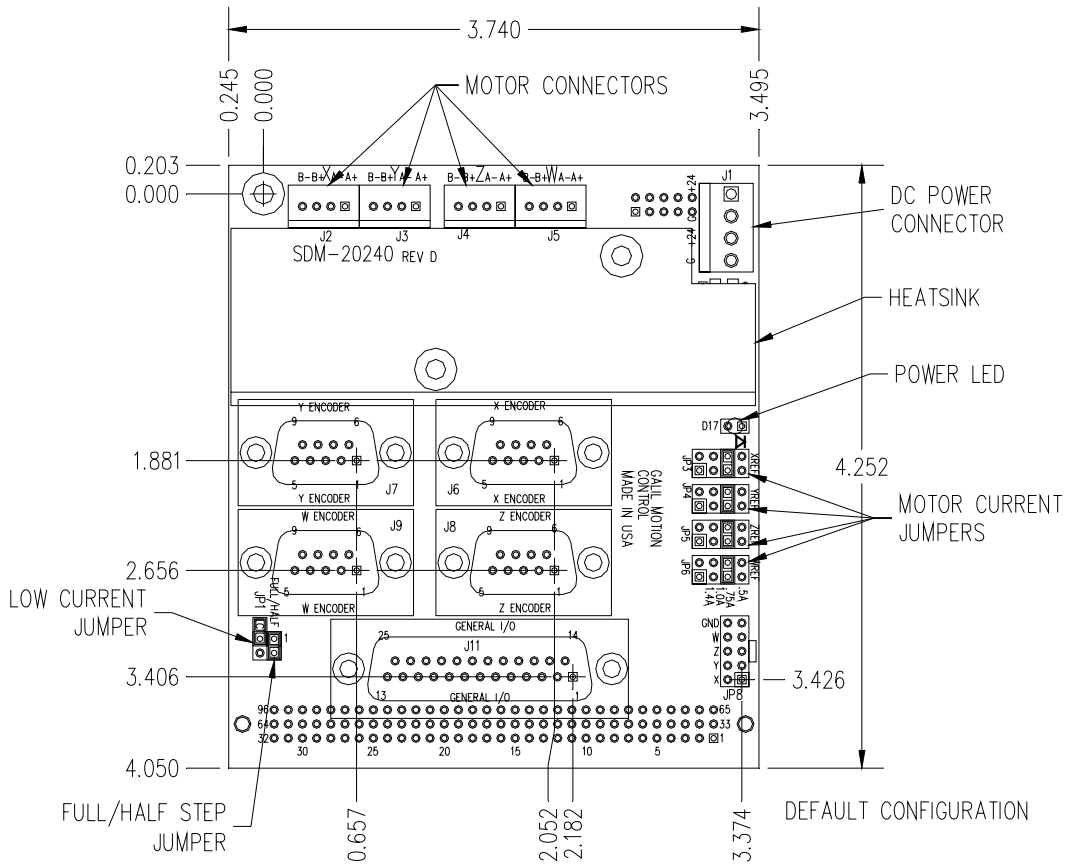

Figure 12 SDM-20240 shown mounted to a DMC-2143-DIN-DC24

Electrical Specifications

DC Supply Voltage:	12-30	VDC
Max Drive Current (per axis)	1.4	Amps (jumper-settable)
Max Step Frequency	3	MHz
Motor Type	Bipolar 2 phase	

Layout



Drawing Not to Scale. For Reference Only. Dimensions are in inches

Figure 13 SDM-20240 Dimensions
Overall Dimensions: 4.25" x 3.70"

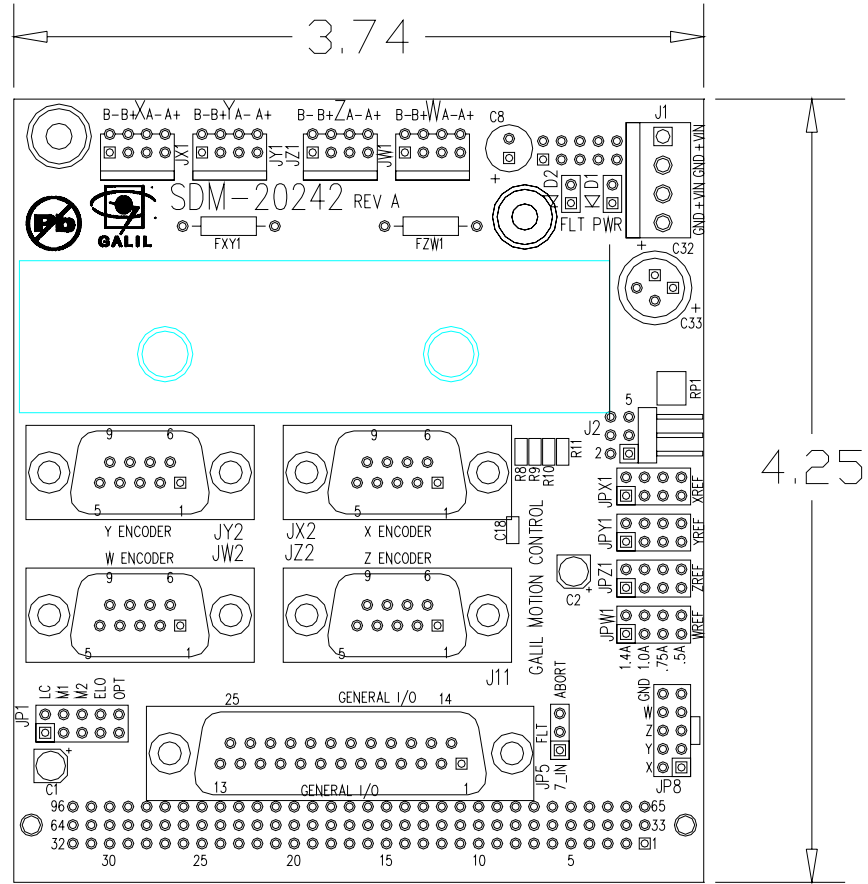

Figure 14 SDM-20242 Layout
 For connector dimensions, see SDM-20240 drawing above

Pinout

J2 - Motor Output X (4pin Molex)
1 XMOA+
2 XMOA-
3 XMOB+
4 XMOB-

J3 - Motor Output Y (4pin Molex)
1 YMOA+
2 YMOA-
3 YMOB+
4 YMOB-

J4 - Motor Output Z (4pin Molex)
1 ZMOA+
2 ZMOA-
3 ZMOB+
4 ZMOB-

J5 - Motor Output W (4pin Molex)
1 WMOA+
2 WMOA-
3 WMOB+
4 WMOB-

J6 - X-axis 9-pin Male D-sub	
1	Forward limit X
2	Home X
3	5V
4	A- X
5	B- X
6	Reverse limit X
7	Ground
8	A+ X
9	B+ X

J7 Y-axis 9-pin Male D-sub	
1	Forward limit Y
2	Home Y
3	5V
4	A- Y
5	B- Y
6	Reverse limit Y
7	Ground
8	A+ Y
9	B+ Y

J8 Z-axis 9-pin Male D-sub	
1	Forward limit Z
2	Home Z
3	5V
4	A- Z
5	B- Z
6	Reverse limit Z
7	Ground
8	A+ Z
9	B+ Z

J9 W-axis 9-pin Male D-sub	
1	Forward limit W
2	Home W
3	5V
4	A- W
5	B- W
6	Reverse limit W
7	Ground
8	A+ W
9	B+ W

J11 I/O 25-pin Male D-sub	
1	Ground
2	Latch X/Input 1
3	Latch Z/Input 3
4	Input 5
5	Input 7
6	Abort
7	Output 1
8	Output 3
9	Output 5
10	Output 7
11	Ground
12	Reset

13	NC
14	5V
15	Latch Y/Input 2
16	Latch W/Input 4
17	Input 6
18	Input 8
19	Encoder-compare output
20	Output 2
21	Output 4
22	Output 6
23	Output 8
24	5V
25	Error

J1 Power	
1 +V (12V-30V)	3 +V (12V-30V)
2 Ground	4 Ground

JP8 – Servo Motor Signals
1 XAEN (X Amp Enable)
2 XMCM (X Motor CMD)
3 YAEN (Y Amp Enable)
4 YMCM (Y Motor CMD)
5 ZAEN (Z Amp Enable)
6 ZMCM (Z Motor CMD)
7 WAEN (W Amp Enable)
8 WMCM (W Motor CMD)
9 GND
10 GND

Mating Connectors

	Connector	Terminal Pins
J1: Power	Molex: 26-03-4041	Molex: 08-50-0189
J2-J5: Motor Leads	Molex: 22-01-3047	Molex: 08-50-0114

Configurations for SDM-20240 & SDM-20242

The SDM-20240 & 20242 have jumpers for setting different functions on the amplifier. The output current per phase can be set as noted in the table below to 0.5, 0.75, 1.0, or 1.4 Amps/phase. Jumpers are also used to control the current level when the motor is holding position and the degree of microstepping. The SDM-20242 has additional jumpers for extra functionality. The following paragraphs give the details of the jumper settings.

Motor Current Setting

Set the Current Reference jumpers for each axis to determine the maximum (peak) output current for each motor. The axes X,Y,Z, and W apply to jumpers JP3, JP4, JP5, and JP6 (SDM-20240) or JPX1, JPY1, JPZ1, and JPW1(SDM-20242) respectively. Four options are available for each axis: 0.5A, 0.75A, 1.0A, and 1.4 A. In figure below, the X-axis is configured for 0.5A, the Y axis as 0.75A, the Z-axis with 1.0 A, and the W axis for 1.4 A. (**Note:** when using the 1.4 A setting, a cooling fan or adequate air flow may be required.)

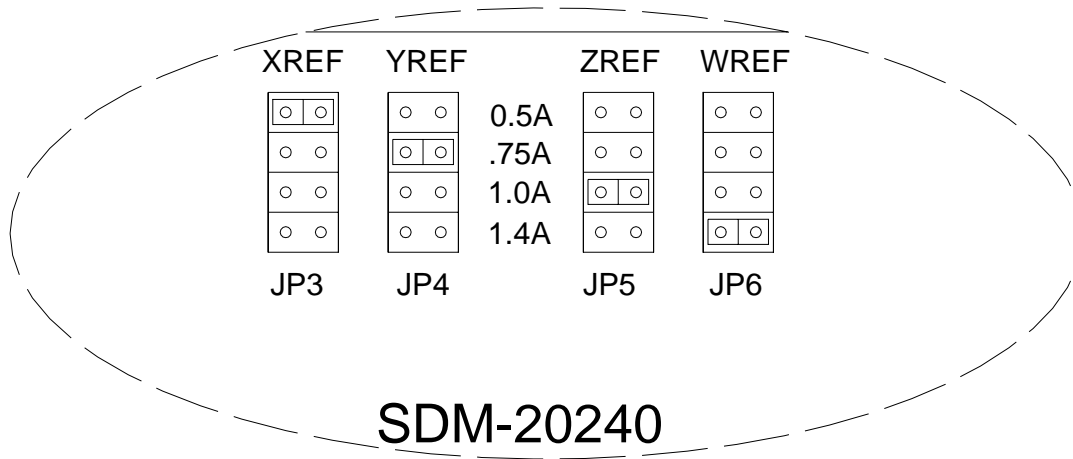

Figure 15 Current Limit Jumper Configuration

Low Current Setting (JP1)

The LC jumper and associated “LC” command have three possible configurations for both the SDM-20240 and SDM-20242:

- LC command set to 1 and LC jumper ON – causes motor to use 25% (50% rev A & B) of peak current while at a “resting” state (profiler is not commanding motion). This is the recommended configuration to minimize heat generation and power consumption.
- LC command set to 1 and LC jumper OFF – turns amplifiers off when at “rest” (not commanding motion).
- LC jumper ON or OFF and LC command set to 0 (default). Full current to drive even when at rest. Proper heat dissipation is critical if using LC0.

The LC command must be entered after MT-2,-2,-2,-2. LC should be set for each axis – so LC1,1,1,1 will cause all axes to operate in “Low Current” mode.

Low Current Setting AMP-20240/20242: LC n,n,n,n,n,n,n

n = 0	100%
n = 1	25% * / 0%
* LC function for SDM 20240 requires jumper installation at JP1, else 0% current occurs.	

SDM-20240 Half Step jumper (JP1) – determines whether pulses from the controller are interpreted by the Driver chips as whole or half step increments.

Half Step Jumper On = Half step

Half Step Jumper Off = Full step

Additional Settings for SDM-20242

Micro Step jumpers (JP1)

Determines whether pulses from the controller are interpreted by the Driver chips as whole, half, or micro-step increments.

No Jumper = Full step

M1 ON only = Half step

M2 ON only = 1/4th step

M1 and M2 ON = 1/16th step

(Note: when running in **full step** mode – the current to the motor is 70% of maximum. All micro-step settings are able to deliver full current.)

Protection Circuitry and Error LED

The SDM-20241 has short circuit protection circuitry as well as under/over voltage and over temperature protection. Here is a list of possible reasons for the Error LED to turn on and stop all motors from operating:

- If the motor leads are shorted together, or shorted to ground
- Power is applied to the controller before the driver board
- Temperature has risen above maximum
- Voltage applied to driver board is too high

When the LED comes on, the error has to be cleared by issuing MO;SH. If the controller is in LC*=1 mode, an LC*=0;LC*=1 command is required to clear the error condition.

ELO (Emergency Lock Out)

The Emergency Lock Out jumper (ELO on JP1) is a jumper setting on the SDM-20242 which configures the driver's behavior when the abort line goes low. With the jumper absent (default), the behavior of the motors is subject to the OE command. When the jumper is installed, the amplifiers will be immediately shut down at a hardware level (bypasses the controller firmware). When the ELO jumper is installed, the OE command should be set to 1. To recover, issue MO;SH.

Fault Output from SDM-20242

The fault output jumper allows the user to choose to bring out the amplifier's error signal to either the Abort line or Input 7 of the controller. With no jumper – the fault signal is not connected to the controller at all. If a jumper is placed between the center pin and towards the side that says 7_IN – then input 7 is used. Conversely, if the jumper is placed between the center pin and the side that says ABORT – the Abort line is jumpered to the fault output.

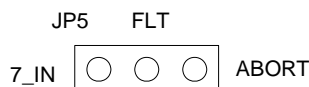

THIS PAGE LEFT BLANK INTENTIONALLY

Chapter 6 AMP-20341

Introduction

The AMP-20341 contains four linear drives for operating small brush-type servo motors. The AMP-20341 requires a $\pm 12-30$ DC Volt input.* Output power is 20 W per amplifier or 60 W total. The gain of each transconductance linear amplifier is 0.1 A/V at 1 A maximum current. The typical current loop bandwidth is 4 kHz. The AMP-20341 uses 15-pin D-sub connectors for encoder and limit connections on each axis and a 25-pin D-sub connector for I/O connections.

* The AMP-20341 replaces the AMP-20340, which accepted a single voltage supply



Figure 16 ICM-20100 (left) and AMP-20341 (right) shown mounted with DMC-2183-DIN

Electrical Specifications

DC Supply Voltage:	+/-12-30 VDC (bipolar)
Max Current (per axis)	1.0 Amps
Amplifier gain:	0.1 A/V
Power output (per channel):	20 W
Total max. power output:	60 W

Layout

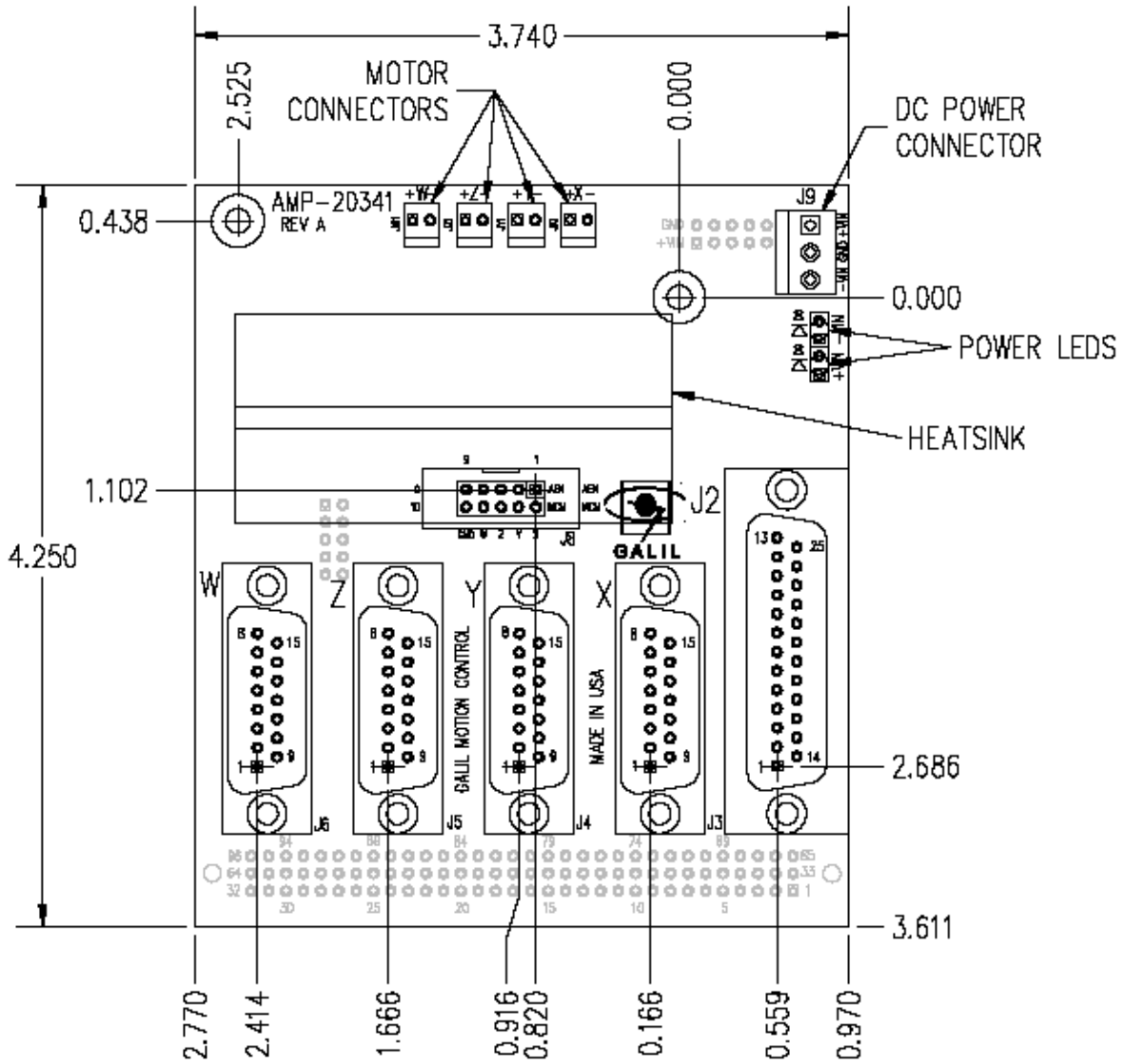

Figure 17 AMP-20341 Hole Dimensions

Pinout

Pin	J3	J4	J5	J6
1	Forward Limit X	Forward Limit Y	Forward Limit Z	Forward Limit W
2	Home X	Home Y	Home Z	Home W
3	5V	5V	5V	5V
4	A-X	A-Y	A-Z	A-W
5	B-X	B-Y	B-Z	B-W
6	I-X	I-Y	I-Z	I-W
7	AA-X	AA-Y	AA-Z	AA-W
8	AB-X	AB-Y	AB-Z	AB-W
9	Reverse Limit X	Reverse Limit Y	Reverse Limit Z	Reverse Limit W
10	Ground	Ground	Ground	Ground
11	A+X	A+Y	A+Z	A+W
12	B+X	B+Y	B+Z	B+W
13	I+X	I+Y	I+Z	I+W
14	AA+X	AA+Y	AA+Z	AA+W
15	AB+X	AB+Y	AB+Z	AB+W

JX - Motor Output X (2pin Molex)	JY - Motor Output Y (2pin Molex)
JX1 XMO+	JY1 YMO+
JX2 XMO-	JY2 YMO-
JZ - Motor Output Z (2pin Molex)	JW - Motor Output W (2pin Molex)
JZ1 ZMO+	JW1 WMO+
JZ2 ZMO-	JW2 WMO-

J2 I/O (25 Pin D-sub)			
1 Ground	8 Output 3	15 Latch Y/Input 2	22 Output 6
2 Latch X/Input 1	9 Output 5	16 Latch W/Input 4	23 Output 8
3 Latch Z/Input 3	10 Output 7	17 Input 6	24 5V
4 Input 5	11 Ground	18 Input 8	25 Error Output *
5 Input 7	12 Reset *	19 Encoder compare output	
6 Abort*	13 NC	20 Output 2	
7 Output 1	14 5V	21 Output 4	* Active Low

J9 Power
1 +V (12 to 30V)
2 Ground
3 -V (-12 to -30V)

Mating Connectors

	Connector	Terminal Pins
J9: Power	Molex: 26-03-4030	Molex: 08-50-0189
JX - JW: Motor Leads	Molex: 22-01-3027	Molex: 08-50-0114

Chapter 7 AMP-20440/20420

Introduction

The AMP-20420 and AMP-20440 are brush style amplifiers with a power capacity of 200 Watts per channel. The amplifier is operational from 18-60 VDC. The amplifier is a transconductance amplifier and will supply a current proportional to a given command signal. The amplifier includes protection against over voltage and over current. The controller below is shown connecting with an AMP-20440.

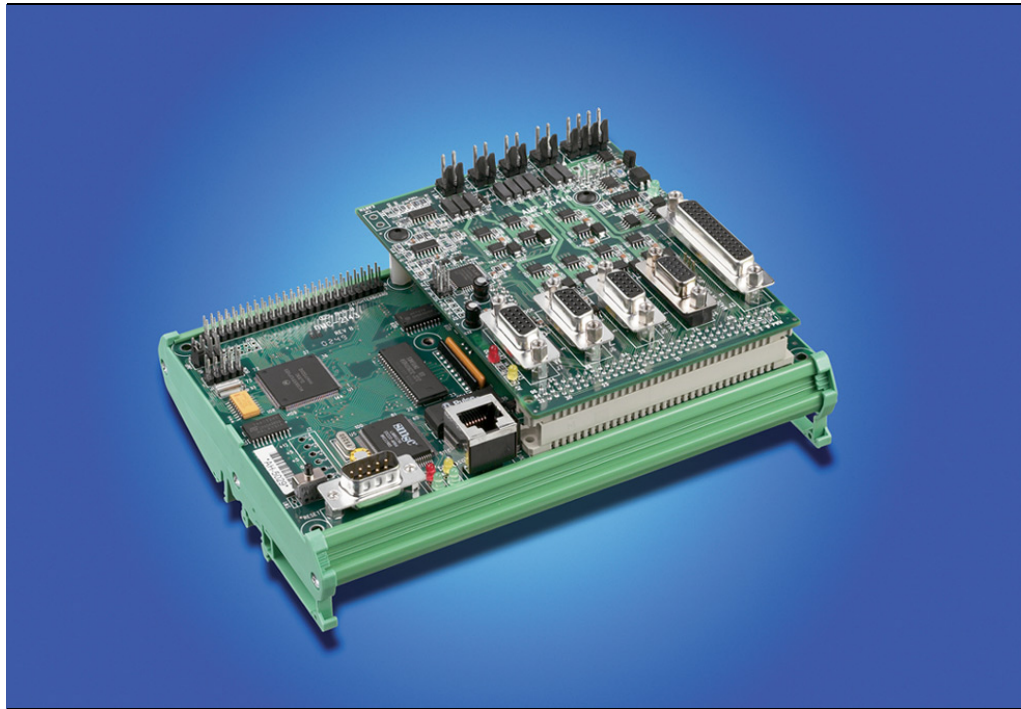
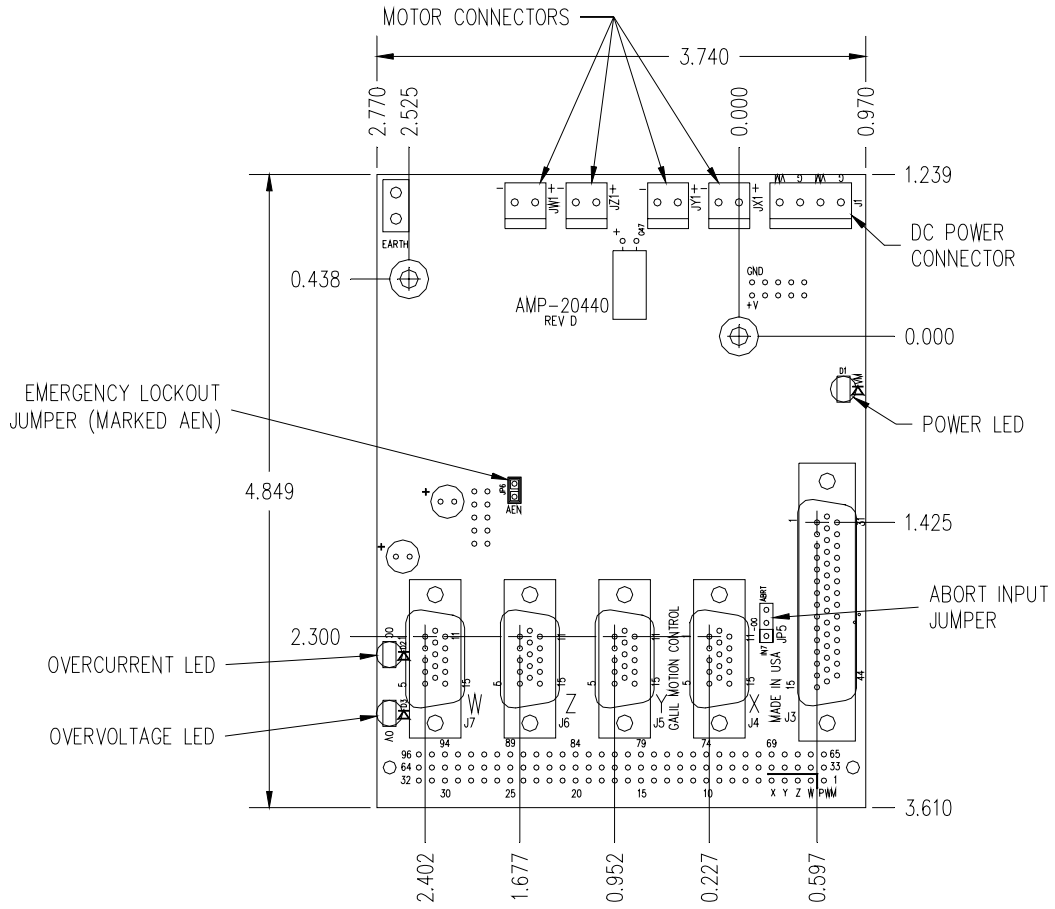

Figure 18 AMP-20440 shown mounted to a DMC-2143-DIN-DC24

Electrical Specifications

DC Supply Voltage:	18-60	VDC
Max Current:	3.3	Amps (continuous and peak)
PWM Frequency:	60	kHz
Minimum Load Inductance:	0.5	mH
Over-Voltage Threshold (OV):	69	volts (resets at 66 volts)

Layout



Drawing Not to Scale. For Reference Only. Dimensions are inches.

Figure 19 AMP-20440 Dimensions
Overall Dimensions: 4.85" x 3.70"

Pinout

J4 X-axis 15-pin Hi-density Female D-sub
1 I+ X
2 B+ X
3 A+ X
4 AB+ X
5 Ground
6 I- X
7 B- X
8 A- X
9 AA- X
10 Forward Limit X
11 AA+ X
12 AB- X
13 Home X
14 Reverse Limit X
15 5V

J5 Y-axis 15-pin Hi-density Female D-sub
1 I+ Y
2 B+ Y
3 A+ Y
4 AB+ Y
5 Ground
6 I- Y
7 B- Y
8 A- Y
9 AA- Y
10 Forward Limit Y
11 AA+ Y
12 AB- Y
13 Home Y
14 Reverse Limit Y
15 5V

J6 Z-axis 15-pin Hi-density Female D-sub
1 I+ Z
2 B+ Z
3 A+ Z
4 AB+ Z
5 Ground
6 I- Z
7 B- Z
8 A- Z
9 AA- Z
10 Forward Limit Z
11 AA+ Z
12 AB- Z
13 Home Z
14 Reverse Limit Z
15 5V

J7 W-axis 15-pin Hi-density Female D-sub
1 I+ W
2 B+ W
3 A+ W
4 AB+ W
5 Ground
6 I- W
7 B- W
8 A- W
9 AA- W
10 Forward Limit W
11 AA+ W
12 AB- W
13 Home W
14 Reverse Limit W
15 5V

J1 Power 4-pin
1 VM+ 18-60 VDC
2 Ground
3 VM+ 18-60 VDC
4 Ground
Mating Connector AMP 770849-4
Mating Connector Pins AMP 770476-1

JX1 Motor Output 2-pin Molex
1 XMO-
2 XMO+

JY1 Motor Output 2-pin Molex
1 YMO-
2 YMO+

JZ1 Motor Output 2-pin Molex
1 ZMO-
2 ZMO+

JW1 Motor Output 2-pin Molex
1 WMO-
2 WMO+
Mating Connector Molex 26-03-4020
Mating Connector Pins Molex 08-50-0189

J3 I/O 44-pin Hi-density Female D-sub
1 NC
2 Output 6
3 Output 8
4 Output 5
5 Output 2
6 Abort* (see Appendix A)
7 Input 6
8 Latch Z / Input 3
9 Y-axis AmpEnable (RevD and greater)
10 Encoder-Compare Output
11 Sign/Dir X
12 Sign/Dir Y

13 Sign/Dir Z
14 Sign/Dir W
15 PWM/Step W
16 W-axis AmpEnable (RevD and greater)
17 Z-axis AmpEnable (RevD and greater)
18 Output 7
19 Output 4
20 Output 1
21 Output 3
22 Input 7
23 Latch W / Input 4
24 Latch X / Input 1
25 NC
26 Motor Command X
27 Motor Command Y
28 Motor Command Z
29 Motor Command W
30 Error Output*
31 NC
32 5V
33 5V
34 Ground
35 Ground
36 Input 8
37 Input 5
38 Latch Y / Input 2
39 NC
40 X-axis AmpEnable (RevD and greater)
41 PWM/Step X
42 PWM/Step Y
43 PWM/Step Z
44 Reset*
*Active Low Signal

Over-Voltage Protection

The AMP-204x0 is protected against over voltage. If the supply voltage to the amplifier exceeds 69 V, the over voltage protection will take effect. The yellow over voltage LED will be lit on the amplifier until the voltage drops below 66 V. It is possible to get into this condition if the power supply voltage is too high, or if the voltage level is raised due to regeneration. If you have very high inertial loads (which may cause regeneration), you may consider using a shunt regulator such as the SR-19900 supplied by Galil. Another important issue to consider is the level of the over voltage protection. You should set the shunt regulator at a voltage level which will still allow for proper operation of the power supply. Note that if you are using the -DC24 option from Galil, the DC-DC converter is capable of receiving voltages up to 36 V. If you need a shunt regulator, you should set the device to limit the voltage to a value less than 36 V. If you are using the -DC48 option, the voltage should be limited to 66 V and it is recommended that you use a supply of 60V or less.

Over-Current Protection

The controller also has protection against over current. Over current will cause the amplifier to be disabled, and can be enabled again from the controller by issuing the MO and then SH command. If you see that the red over current LED is lit on the amplifier, there is a problem with either your system or the amplifier. The most likely reason is because of a short between the motor phases or between the motor phases and ground. This indicates either a wiring problem, or a faulty motor.

Please review the table below to configure the options for the over current signal. If you choose the option of connecting the over current signal to the abort line, all axes in motion and the controller's application program will be aborted. If you choose to transmit the signal to input 7, then an application program can be set to interrupt on this input, and run a user defined program. For further information on using the abort, or the input interrupt routines, refer to the user manual supplied with the motion controller.



<p style="text-align: center;">-OC</p> <p>IN7  ABRT</p> <p style="text-align: center;">JP5</p>	<p>No jumper (factory default): causes the controller to take no action when an over-current condition occurs (AMP-204x0 amplifier still disables).</p>
<p style="text-align: center;">-OC</p> <p>IN7  ABRT</p> <p style="text-align: center;">JP5</p>	<p>OC-IN7: Place jumper between OC and IN7 to transmit over-current condition to the controller's General-Purpose Digital Input 7. Use the AE command to allow #AMPERR to run and TA to report status</p>
<p style="text-align: center;">-OC</p> <p>IN7  ABRT</p> <p style="text-align: center;">JP5</p>	<p>OC-ABRT: Place jumper between OC and ABRT to transmit over-current condition to the controller's Abort Input.</p>

Figure 20 AMP-204x0 Overcurrent jumper configurations

Abort Input Options

See Appendix A.

Chapter 8 ICM-20500

Introduction

The ICM-20500 provides a screw terminal interface for the AMP-205x0. The unit also provides optical isolation on digital inputs and outputs to interface with up to 24V I/O. The first four outputs are high power outputs capable of providing up to 500 mA at up to 24 VDC.

The ICM-20500 is also available with D-type connectors instead of screw terminals (order as ICM-20500-DTYPE). This provides optical isolation of the I/O when using an AMP-205x0. The D-type connectors include four 15-pin high density connectors and one 44-pin high-density connector. The pinout of the 15-pin connectors is the same as the AMP-205x0. The 44-pin connections are the same except for the following four signals:

- Pin 9 Output Supply
- Pin 25 Input Common (INCOM)
- Pin 39 Output Return
- Pin 40 Limit Switch Common (LSCOM)

Note that the ability to connect to external amplifiers on X and Y is lost when using an ICM-20500-DTYPE.

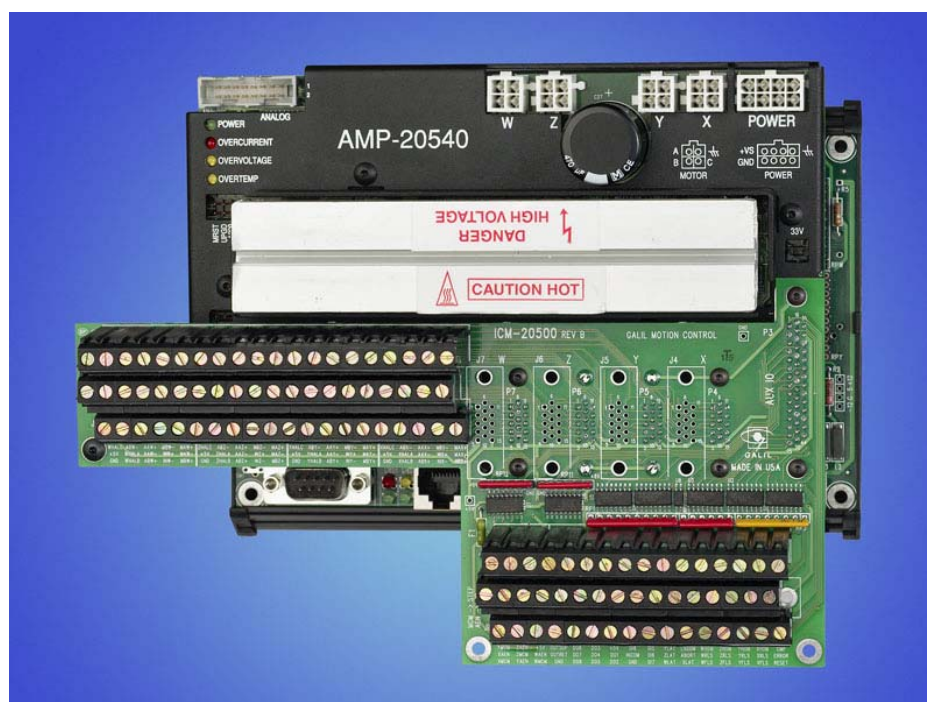
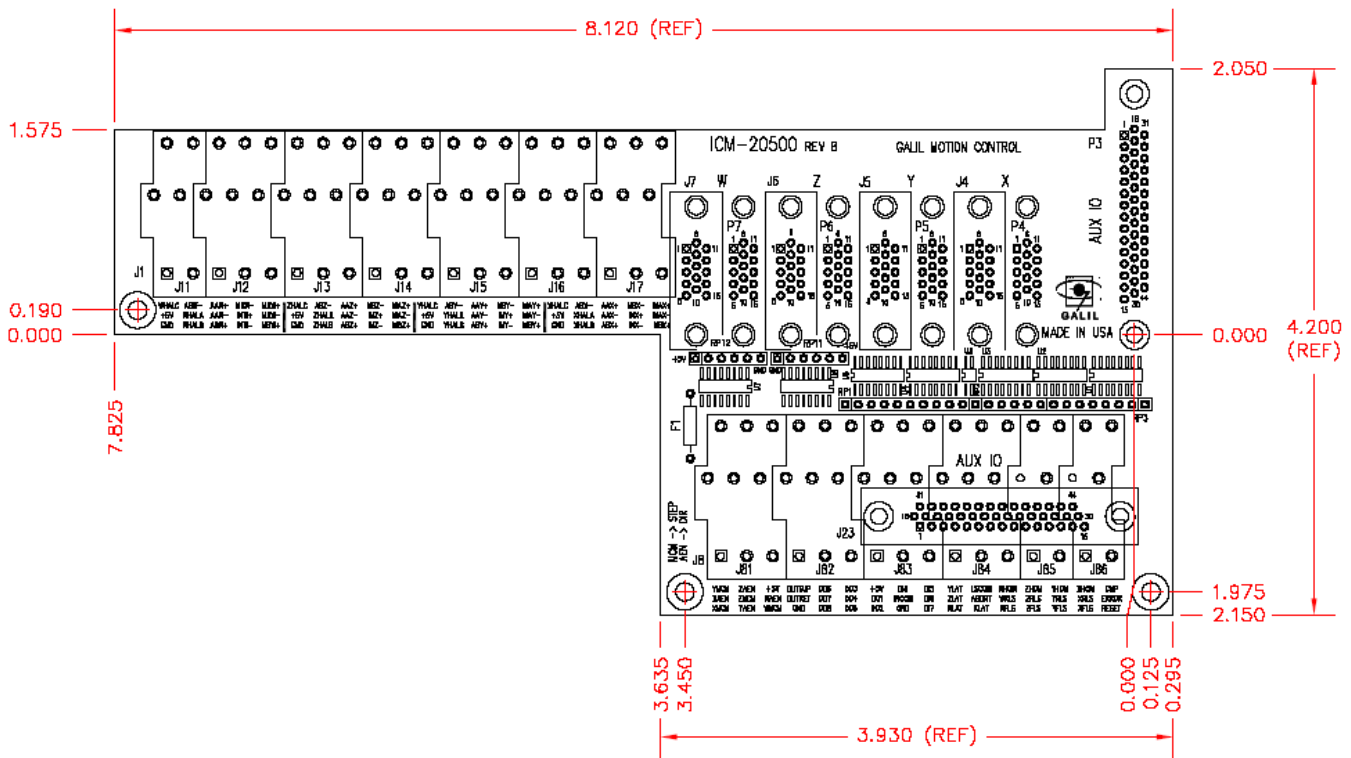

Figure 21 ICM-20500 shown mounted to a DMC-2143 and AMP-20540

Electrical Specifications

Input Common Max Voltage	28 VDC
Output Common Max Voltage	28 VDC
Max Drive Current per Output	0.5 A (outputs 1-4), 25 mA (outputs 5-8)
Minimum Current to turn on Inputs	1 mA

Layout



Drawing Not to Scale. For Reference Only. Dimensions are inches.

Figure 22 ICM-20500 Dimensions
Overall Dimensions: 8.12" x 4.20"

Pinout

ICM-20500 (standard product with screw terminals)

1	W Hall Phase C	37	Y Aux Encoder A +	73	Digital Output 6 (25 mA)
2	+ 5 V (Power output)	38	Y Aux Encoder A -	74	Digital Output 7 (25 mA)
3	GND (Power return)	39	Y Aux Encoder B +	75	Digital Output 8 (25 mA)
4	W Aux Encoder B -	40	Y Main Encoder B -	76	Digital Output 3 (0.5 A)
5	W Hall Phase A	41	Y Main Encoder I +	77	Digital Output 4 (0.5 A)
6	W Hall Phase B	42	Y Main Encoder I -	78	Digital Output 5 (25 mA)
7	W Aux Encoder A +	43	Y Main Encoder A +	79	+ 5 V (Power output)
8	W Aux Encoder A -	44	Y Main Encoder A -	80	Digital Output 1 (0.5 A)
9	W Aux Encoder B +	45	Y Main Encoder B +	81	Digital Output 2 (0.5 A)
10	W Main Encoder B -	46	X Hall Phase C	82	Digital Input 8
11	W Main Encoder I +	47	+ 5 V (Power output)	83	INCOM
12	W Main Encoder I -	48	GND (Power return)	84	GND (Power return)
13	W Main Encoder A +	49	X Aux Encoder B -	85	Digital Input 5
14	W Main Encoder A -	50	X Hall Phase A	86	Digital Input 6
15	W Main Encoder B +	51	X Hall Phase B	87	Digital Input 7
16	Z Hall Phase C	52	X Aux Encoder A +	88	Y Latch / DI 2
17	+ 5 V (Power output)	53	X Aux Encoder A -	89	Z Latch / DI 3
18	GND (Power return)	54	X Aux Encoder B +	90	W Latch / DI 4
19	Z Aux Encoder B -	55	X Main Encoder B -	91	LSCOM
20	Z Hall Phase A	56	X Main Encoder I +	92	Abort Input
21	Z Hall Phase B	57	X Main Encoder I -	93	X Latch / DI 1
22	Z Aux Encoder A +	58	X Main Encoder A +	94	W Home Input
23	Z Aux Encoder A -	59	X Main Encoder A -	95	W Reverse Limit
24	Z Aux Encoder B +	60	X Main Encoder B +	96	W Forward Limit
25	Z Main Encoder B -	61	Y Motor Command	97	Z Home Input
26	Z Main Encoder I +	62	X Amp Enable	98	Z Reverse Limit
27	Z Main Encoder I -	63	X Motor Command	99	Z Forward Limit
28	Z Main Encoder A +	64	Z Amp Enable	100	Y Home Input
29	Z Main Encoder A -	65	Z Motor Command	101	Y Reverse Limit
30	Z Main Encoder B +	66	Y Amp Enable	102	Y Forward Limit
31	Y Hall Phase C	67	+ 5 V (Power output)	103	X Home Input
32	+ 5 V (Power output)	68	W Amp Enable	104	X Reverse Limit
33	GND (Power return)	69	W Motor Command	105	X Forward Limit
34	Y Aux Encoder B -	70	Output Supply	106	Output Compare
35	Y Hall Phase A	71	Output Return	107	Error (Output)
36	Y Hall Phase B	72	GND (Power return)	108	Reset (Input)

ICM-20500-DTYPE (D-shell connectors and no screw terminals)

The pinout of 15-pin connectors is the same as the AMP-205x0. The 44-pin connections are the same except for the following four signals:

- Pin 9 Output Supply
- Pin 25 Input Common (INCOM)
- Pin 39 Output Return
- Pin 40 Limit Switch Common (LSCOM)

Configuration

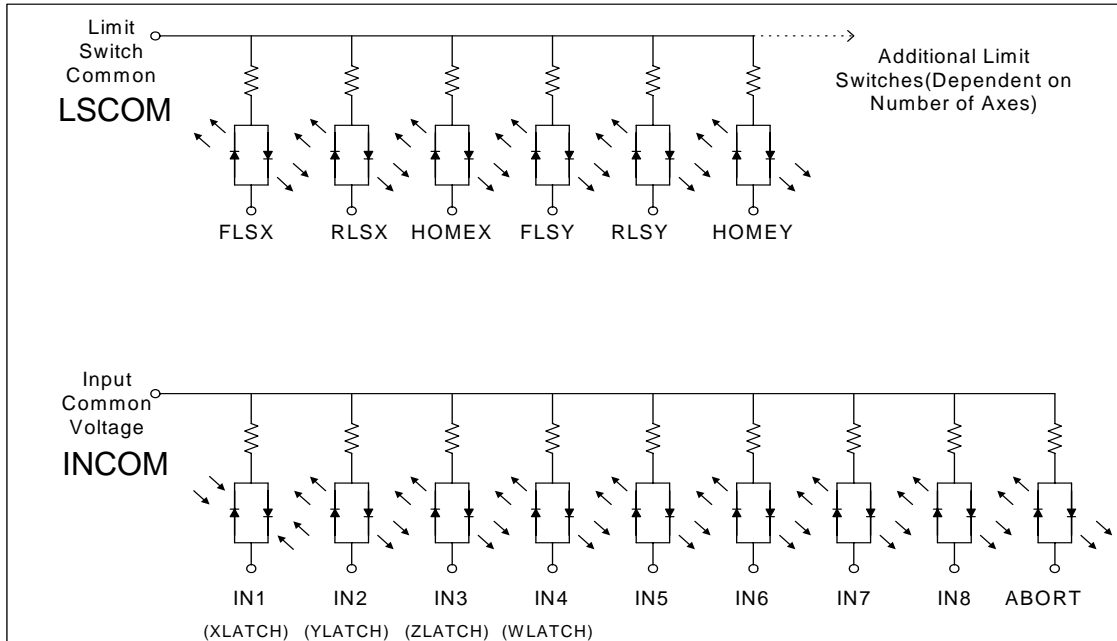

Figure 23 ICM-20500 Digital Inputs

The schematic above shows the digital input configuration. For digital inputs 1 to 8, INCOM connects to the positive (+) terminal of an external DC supply for a sourcing configuration. For a sinking configuration, the negative (-) supply terminal is connected instead. The same approach is applied to the Home and Limit switch inputs with LSCOM.

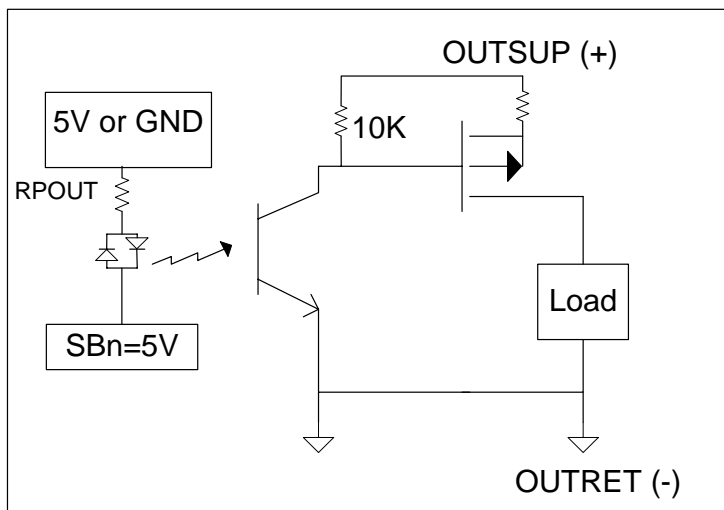

Figure 24 ICM-20500 Digital Outputs 1 to 4

On the digital outputs, the first four outputs (Outputs 1 to 4) are high power outputs capable of providing up to 500 mA at up to 24 VDC. An external DC supply must be connected between Output Supply and Output Return. The other four outputs (Outputs 5 to 8) are opto-isolated and can deliver up to 25 mA at up to 24 VDC.

The diagram refers only to outputs 1 to 4. On outputs 5 to 8, there is no FET on final stage of the output, only the opto-isolator.

The polarity of outputs 1-4 may be reversed by flipping RP11 180 degrees. The polarity of outputs 5-8 may be reversed by flipping RP12 180 degrees.

Chapter 9 AMP-20540/20520

Introduction

The AMP-20540 (four-axis) and AMP-20520 (two-axis) are multi-axis brush/brushless amplifiers that are capable of handling 500 watts of continuous power per axis. The AMP-20540/20520 Brushless drive modules are connected to a DMC-21x3 controller via the 96 pin DIN connector. The standard amplifier accepts DC supply voltages from 18-60 VDC. Note that the -DC48 option is only rated to 72 VDC. The 80 V option requires the user to provide +/- 12 V and 5 V supplies to the controller separate from the amplifier. If higher voltages are required, please contact Galil. Like the DB-28040, the AMP-205x0 family provides for the addition of 8 analog input to the DMC-21x3. The analog inputs accept +/- 10 V input and have a resolution of 12 bits; a 16 bit option is available.



Figure 25 AMP-20540

Electrical Specifications

The amplifier is a brush/brushless trans-conductance PWM amplifier. The amplifier operates in torque mode, and will output a motor current proportional to the command signal input.

Supply Voltage:	18-60 VDC (Up to 8 VDC optional)
Continuous Current:	7 Amps
Peak Current	10 Amps
Nominal Amplifier Gain	0.4, 0.7, and 1.0 A/V
Switching Frequency	60 kHz (up to 140 kHz available-contact Galil)
Minimum Load Inductance:	0.5 mH (low inductance option available)
Brushless Motor Commutation angle	120° (60° option available)

Layout

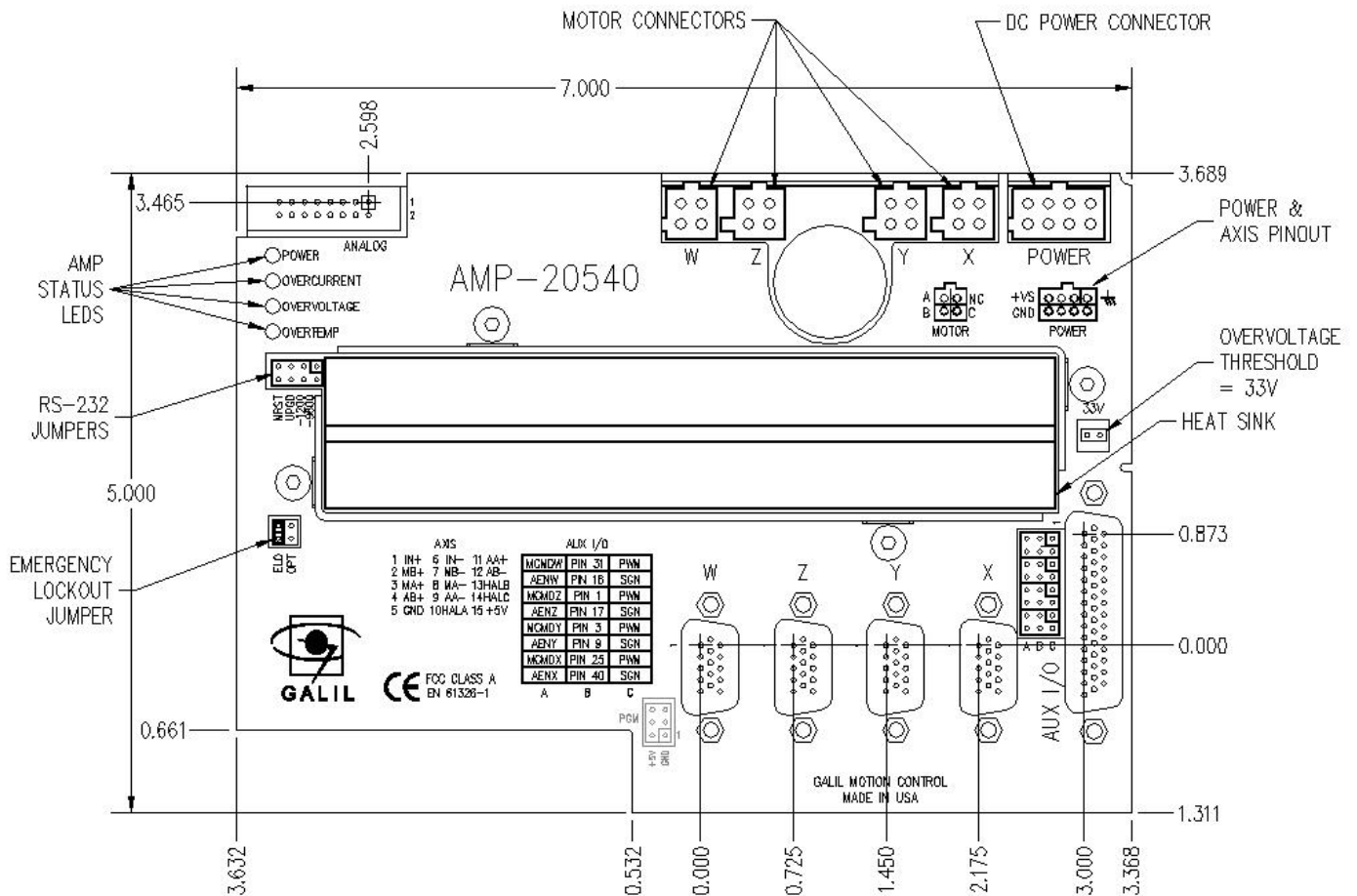

Drawing Not to Scale. For Reference Only. Dimensions are inches.

Figure 26 AMP-20540 Dimensions
Overall Dimensions: 6.92" x 4.85"

Pinout

J4 - X-axis 15-pin HD Female D-sub
01 I+ X
02 B+ X
03 A+ X
04 AB+ X
05 GND
06 I- X
07 B- X
08 A- X
09 AA- X
10 Hall X A
11 AA+ X
12 AB- X
13 Hall X B
14 Hall X C
15 5V

J5 - Y-axis 15-pin HD Female D-sub
01 I+ Y
02 B+ Y
03 A+ Y
04 AB+ Y
05 GND
06 I- Y
07 B- Y
08 A- Y
09 AA- Y
10 Hall Y A
11 AA+ Y
12 AB- Y
13 Hall Y B
14 Hall Y C
15 5V

J6 - Z-axis 15-pin HD Female D-sub
01 I+ Z
02 B+ Z
03 A+ Z
04 AB+ Z
05 GND
06 I- Z
07 B- Z
08 A- Z
09 AA- Z
10 Hall Z A
11 AA+ Z
12 AB- Z
13 Hall Z B
14 Hall Z C
15 5V

J7 - W-axis 15-pin HD Female D-sub
01 I+ W
02 B+ W
03 A+ W
04 AB+ W
05 GND
06 I- W
07 B- W
08 A- W
09 AA- W
10 Hall W A
11 AA+ W
12 AB- W
13 Hall W B
14 Hall W C
15 5V

JX1 - Motor Output X (4-pin)
NC
2 X axis phase A
3 X axis phase C
4 X axis phase B

JY1 - Motor Output Y (4-pin)
NC
2 Y axis phase A
3 Y axis phase C
4 Y axis phase B

JZ1 - Motor Output Z (4-pin)
NC
2 Z axis phase A
3 Z axis phase C
4 Z axis phase B

JW1 - Motor Output W (4-pin)
NC
2 W axis phase A
3 W axis phase C
4 W axis phase B

J3 I/O 44-pin HD Female D-sub	
01 PWM/MCMTD Z	23 W Latch/Input 4
02 Output 6	24 X Latch/Input 1
03 Output 8	25 PWM/MCMTD X
04 Output 5	26 X Home
05 Output 2	27 Y Home
06 Abort (see Appendix A)	28 Z Home
07 Input 6	29 W Home
08 Z Latch/Input 3	30 Error Out
09 SIGN/AEN Y	31 PWM/MCMTD W
10 Output Compare	32 5V
11 Reverse Limit X	33 5V
12 Reverse Limit Y	34 Ground
13 Reverse Limit Z	35 Ground
14 Reverse Limit W	36 Input 8
15 Forward Limit W	37 Input 5
16 SIGN/AEN W	38 Y Latch/Input 2
17 SIGN/AEN Z	39 PWM/MCMTD Y
18 Output 7	40 SIGN/AENX
19 Output 4	41 Forward Limit X
20 Output 1	42 Forward Limit Y
21 Output 3	43 Forward Limit Z
22 Input 7	44 Reset

J1 Power (8-pin)
1 Earth
2 +VDC (18V-60V)
3 +VDC (18V-60V)
4 +VDC (18V-60V)
5 GND
6 GND
7 GND
8 GND

J11 – Analog Input- 16 pin IDC Header	
01 GND	09 Analog Input 7
02 GND	10 Analog Input 8
03 Analog Input 1	11 GND
04 Analog Input 2	12 GND
05 Analog Input 3	13 -12V
06 Analog Input 4	14 +12V
07 Analog Input 5	15 5V
08 Analog Input 6	16 GND

Mating Connectors

	Connector	Terminal Pins
J1: DC Power Connector	8-pin Mini Universal MATE-N-LOK AMP# 770579-1	AMP# 170361-1
JX1, JY1, JZ1, and JW1: 4-pin Motor Lead Connector	4-pin Mini Universal MATE-N-LOK AMP# 172167-1	AMP# 170361-1

Operation

Brushless Motor Setup

Note: If you purchased a Galil motor with the amplifier, it is ready for use. No additional setup is necessary.

To begin the setup of the brushless motor and amplifier, it is first necessary to have communications with the motion controller. Refer to the user manual supplied with your controller for questions regarding controller communications. It is also necessary to have the motor hardware connected and the amplifier powered to begin the setup phase. After the encoders and motor leads are connected, the controller and amplifier need to be configured correctly in software. Take all appropriate safety precautions. For example, set a small error limit ($ER^*=1000$), a low torque limit ($TL^*=3$), and set off on Error to 1 for all axes ($OE^*=1$). Review the command reference and controller user manual for further details.

There are 3 settings for the amplifier gain: 0.4 A/V, 0.7 A/V, and 1.0 A/V. If the gain is set to 0.7 A/V, a torque limit of 3 ($TL_n=3$) will allow the amplifier to output no more than 2.1 amps of current on the specified axis. The controller has been programmed to test whether the Hall commutation order is correct. To test the commutation for the X axis, issue the BS command ($BSX= n,m$). The controller will attempt to move the motor through one revolution. If the motor is unable to move, the controller will return “unknown Hall transition”, check wiring, and execute BS again’. It may be necessary to issue more voltage to create motion. The default for the BS command is $BS_n=0.25,1000$ which will send 0.25 volts to the amplifier for 1 second. $BSX=0.5,300$ will issue 0.5 volts from the controller for 300 milliseconds. If the controller is able to move the motor and the Hall transitions are not correct, the controller will alert the operator and recommend which motor phases to change. For example, the controller might return “Wire A to Terminal B, Wire B to Terminal A.” If the controller finds that the commutation order is correct, but the motor would run away due to positive feedback, the controller will prompt the user to “Wire Phase B to C and C to B. Exchange Hall Sensors A and B...”. After making any necessary changes to the motor phase wiring, confirm correct operation by reissuing the BS command. Once the axis is wired correctly, the controller is ready to perform closed-loop motion.

Brushless Amplifier Software Setup

Select the amplifier gain that is appropriate for the motor. The amplifier gain command (AG) can be set to 0, 1, or 2 corresponding to 0.4, 0.7, and 1.0 A/V. In addition to the gain, peak and continuous torque limits can be set through TK and TL respectively. The TK and TL values are entered in volts on an axis by axis basis. The peak limit will set the maximum voltage that will be output from the controller to the amplifier. The continuous current will set what the maximum average current is over a one second interval. The following figure captured with WSDK is indicative of the operation of the continuous and peak operation. In this figure, the continuous limit was configured for 2 volts, and the peak limit was configured for 10 volts.

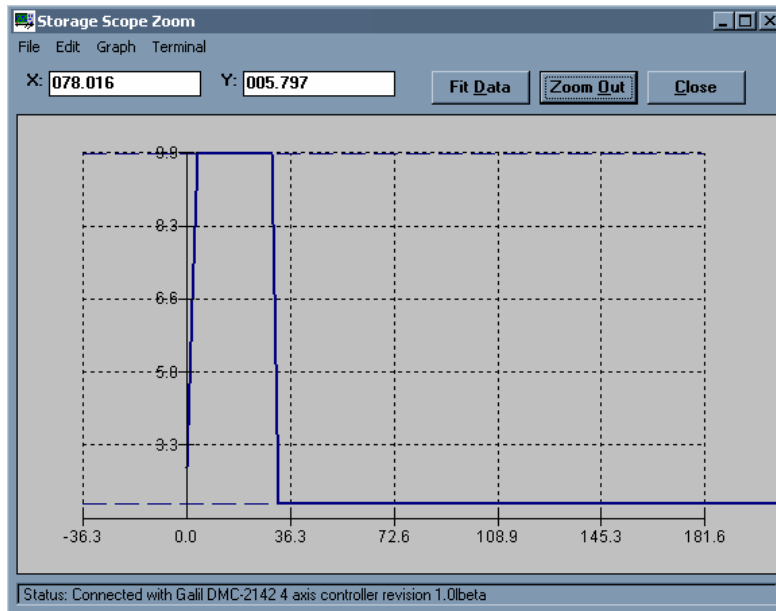

Figure 27 Peak Current Operation (DMC-2143 and AMP-20540)

With the AMP-20540 and 20520, the user is also given the ability to choose between normal and high current bandwidth (AU). In addition, the user can calculate what the bandwidth of the current loop is for their specific combination (AW). To select normal current loop gain for the X axis and high current loop gain for the Y axis, issue AU 0,1. The command AW is used to calculate the bandwidth of the amplifier using the basic amplifier parameters. To calculate the bandwidth for the X axis, issue AWX=v,l,n where v represents the DC voltage input to the card, l represents the inductance of the motor in millihenries, and n represents 0 or 1 for the AU setting.

Note: For most applications, unless the motor has more than 5 mH of inductance with a 24V supply, or 10 mH of inductance with a 48 volts supply, the normal current loop bandwidth option should be chosen. AW will return the current loop bandwidth in Hertz.

Brush Amplifier Operation

The AMP-20540 and AMP-20520 also allow for brush operation. To configure an axis for brush-type operation, connect the 2 motor leads to Phase A and Phase B connections for the axis. Connect the encoders, homes, and limits as required. Set the controller into brush-axis operation by issuing BR n,n,n,n. By setting n=1, the controller will operate in brushed mode on that axis. For example, BR0,1,0,0 sets the Y-axis as brush-type, all others as brushless. If an axis is set to brush-type, the amplifier has no need for the Hall inputs. These inputs can subsequently be used as general-use inputs, queried with the QH command. The gain settings for the amplifier are identical for the brush and brushless operation. The gain settings can be set to 0.4, 0.7, or 1.0 A/V, represented by gain values of 0, 1, and 2 (e.g.. AG 0,0,2,1). The current loop gain AU can also be set to either 0 for normal, or 1 for high current loop gain.

Using External Amplifiers

The AMP-205x0 breaks out the step/direction or amplifier enable/motor command signals to control an external servo or stepper amplifier. For example, a machine might have two axes that use the AMP-20520 and two stepper axes that use external drivers. The pulse and direction signals are accessed through the high density 44-pin D-sub connector. The same connector pins are used to bring out the amplifier enable and motor command line. Which signals are brought

out is set via jumpers (see figure below). If no jumpers are installed (factory default), the corresponding pins on the 44-pin connector will be no-connects. In this example, W axis will output the motor command on pin 31 and amplifier enable on pin 16. The Z axis will output PWM (Step) and Sign (Direction) to the appropriate pins.

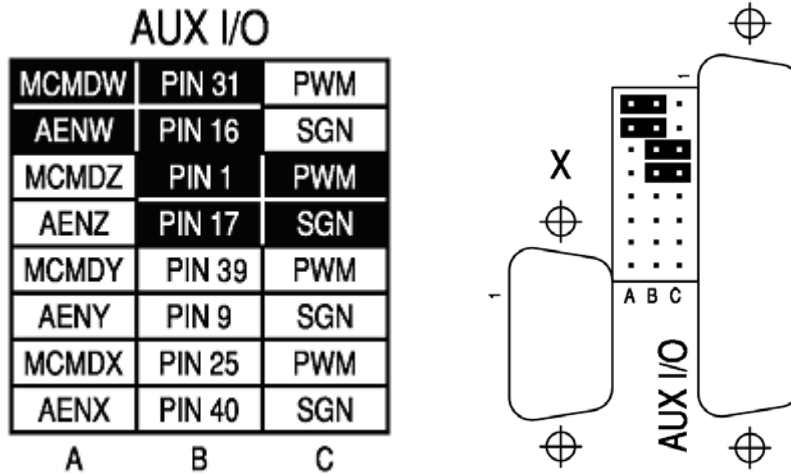

Figure 28 The W-axis is configured for an external servo amplifier and Z for an external stepper amplifier

Error Monitoring and Protection

The amplifier is protected against over-voltage, under-voltage, over-temperature, and over-current for brush and brushless operation. The controller will also monitor for illegal Hall states (000 or 111 with 120° phasing). The controller will monitor the error conditions and respond as programmed in the application. The errors are monitored via the TA command. TA n may be used to monitor the errors with n = 0, 1, 2, or 3. The command will return an eight bit number representing specific conditions. TA0 will return errors with regard to under voltage, over voltage, over current, and over temperature. TA1 will return hall errors on the appropriate axes, TA2 will monitor if the amplifier current exceeds the continuous setting, and TA3 will return if the ELO has occurred as a result of a hard abort input.

The user also has the option to include the special label #AMPERR in their program to handle soft or hard errors. As long as a program is executing in thread zero, and the #AMPERR label is included, when an error is detected, the program will jump to the label and execute the user defined routine. Note that the TA command is a monitoring function only, and does not generate an error condition. The over voltage condition will not permanently shut down the amplifier or trigger the #AMPERR routine. The amplifier will be momentarily disabled; when the condition goes away, the amplifier will continue normal operation assuming it did not cause the position error to exceed the error limit.

Hall Error Protection

During normal operation, the controller should not have any Hall errors. Hall errors can be caused by a faulty Hall-effect sensor or a noisy environment. If at any time the Halls are in an invalid state, the appropriate bit of TA1 will be set. The state of the Hall inputs can also be monitored through the QH command. Hall errors will cause the amplifier to be disabled if OE 1 is set, and will cause the controller to enter the #AMPERR subroutine if it is included in a running program.

Under-Voltage Protection

If the supply to the amplifier drops below 12 VDC, the amplifier will be disabled. The amplifier will return to normal operation once the supply is raised above the 12V threshold; bit 3 of the error status (TA0) will tell the user whether the supply is in the acceptable range.

Over-Voltage Protection

If the voltage supply to the amplifier rises above 68 VDC, then the amplifier will automatically disable. The amplifier will re-enable when the supply drops below 66 V. This error is monitored with bit 1 of the TA0 command. This protection is configurable to activate at 34V and re-enable at 33V by placing a jumper onto JP5.

Over-Current Protection

The amplifier also has circuitry to protect against over-current. If the total current from the supply exceeds 40 A, the amplifier will be disabled. The amplifier will not be re-enabled until the SH command has been sent or the controller is reset. Since the AMP-20540 is a trans-conductance amplifier, the amplifier will never go into this mode during normal operation. The amplifier will be shut down regardless of the setting of OE, or the presence of the #AMPERR routine. Bit 0 of TA0 will be set.

Note: If this fault occurs, it is indicative of a problem at the system level. An over-current fault is usually due to a short across the motor leads or a short from a motor lead to ground.

Over-Temperature Protection

The controller is also equipped with over-temperature protection. If the average heat sink temperature rises over 110°C, then the amplifier will shut down. Bit 2 of TA0 will be set. The amplifier will re-enable when the temperature drops below 110 °C. This error will trigger the #AMPERR routine if included, and the user may decide whether to disable the amplifier.

Abort Input Options

See Appendix A.

Chapter 10 AMP-20542

Introduction

The AMP-20542 is a four-axis PWM servo amplifier designed for direct plug-in to the DMC-21x3 motion controller. It requires a single input DC power supply of 18-60V, is capable of handling up to 200 W continuous per axis, and is rated at 3.3A continuous, 5A peak. The axes are individually software configurable for brush or brushless operation, as are the axes gains of 0.1, 0.25, or 0.5 A/V.

There are two software-configurable modes of operation to suit low inductance motors. These modes are Inverter (for motors with 500 μ H or greater inductance) and Chopper (for motors with 200-500 μ H inductance), configured by the AU command. The amplifier cannot be used with controllers other than the DMC-21x3.

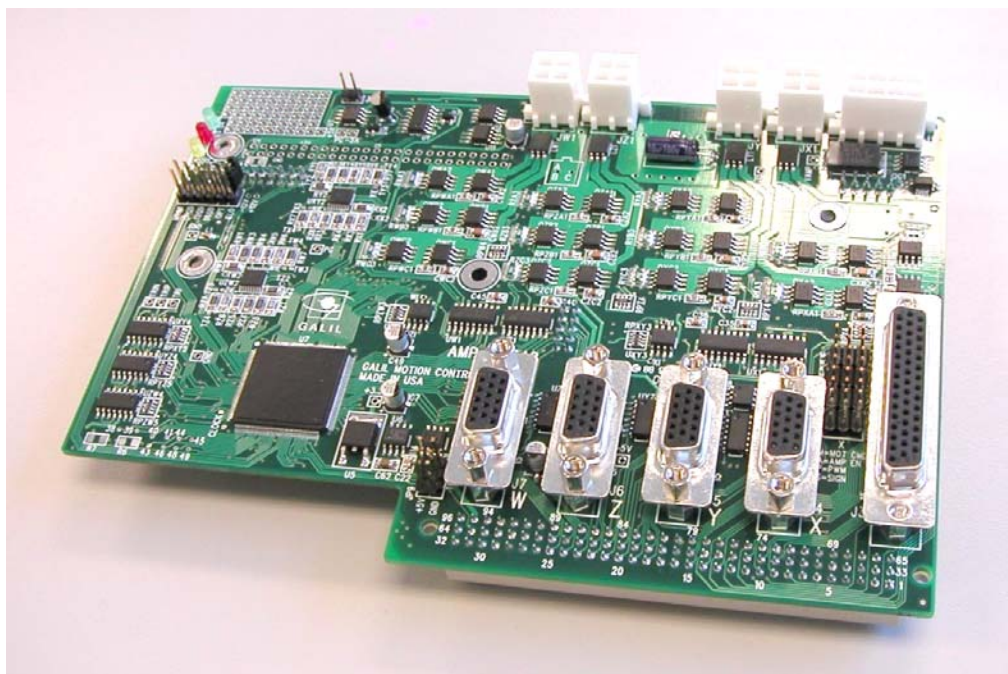

Figure 29 AMP-20542 PWM Servo Amplifier

Electrical Specifications

The amplifier is a brush/brushless PWM amplifier. The amplifier operates in torque mode, and will output a motor current proportional to the command signal input.

Supply Voltage:	18-60 VDC
Continuous Current:	3.3 Amps
Peak Current	5 Amps
Nominal Amplifier Gain	0.1, 0.25, and 0.5 A/V
Switching Frequency	60 kHz
Minimum Load Inductance:	0.2 or 0.5 mH (software-configurable)
Brushless Motor Commutation angle	120°

Layout

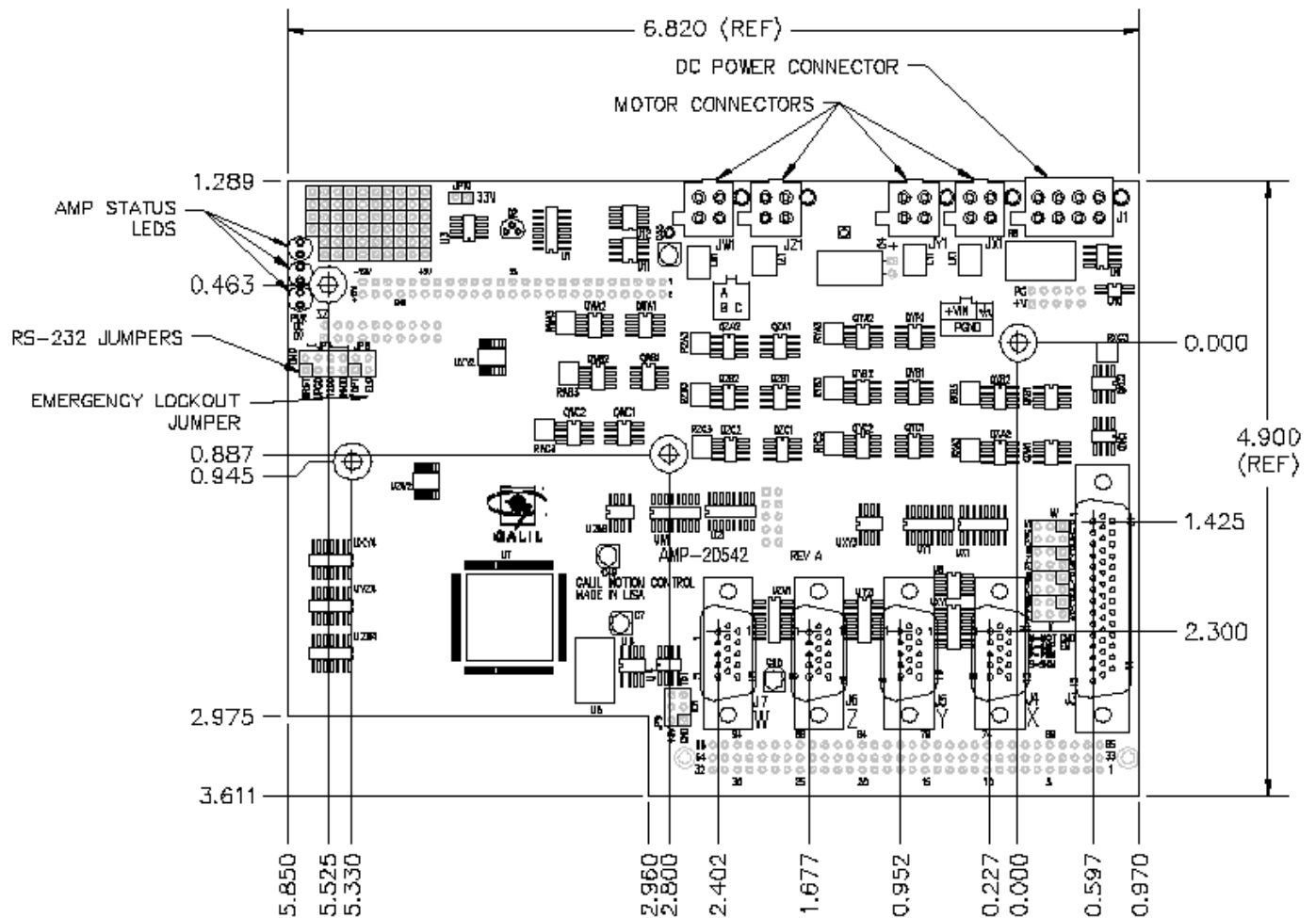

Drawing Not to Scale. For Reference Only. Dimensions are inches.

Figure 30 AMP-20542 Dimensions
Overall Dimensions: 6.82" x 4.90"

Pinout

J4 - X-axis 15-pin HD Female D-sub
01 I+ X
02 B+ X
03 A+ X
04 AB+ X
05 GND
06 I- X
07 B- X
08 A- X
09 AA- X
10 Hall X A
11 AA+ X
12 AB- X
13 Hall X B
14 Hall X C
15 5V

J5 - Y-axis 15-pin HD Female D-sub
01 I+ Y
02 B+ Y
03 A+ Y
04 AB+ Y
05 GND
06 I- Y
07 B- Y
08 A- Y
09 AA- Y
10 Hall Y A
11 AA+ Y
12 AB- Y
13 Hall Y B
14 Hall Y C
15 5V

J6 - Z-axis 15-pin HD Female D-sub
01 I+ Z
02 B+ Z
03 A+ Z
04 AB+ Z
05 GND
06 I- Z
07 B- Z
08 A- Z
09 AA- Z
10 Hall Z A
11 AA+ Z
12 AB- Z
13 Hall Z B
14 Hall Z C
15 5V

J7 - W-axis 15-pin HD Female D-sub
01 I+ W
02 B+ W
03 A+ W
04 AB+ W
05 GND
06 I- W
07 B- W
08 A- W
09 AA- W
10 Hall W A
11 AA+ W
12 AB- W
13 Hall W B
14 Hall W C
15 5V

JX1 - Motor Output X (4-pin)
1 Earth
2 X axis phase A
3 X axis phase C
4 X axis phase B

JY1 - Motor Output Y (4-pin)
1 Earth
2 Y axis phase A
3 Y axis phase C
4 Y axis phase B

JZ1 - Motor Output Z (4-pin)
1 Earth
2 Z axis phase A
3 Z axis phase C
4 Z axis phase B

JW1 - Motor Output W (4-pin)
1 Earth
2 W axis phase A
3 W axis phase C
4 W axis phase B

J3 I/O 44-pin HD Female D-sub	
01 PWM/MCMTD Z	23 W Latch/Input 4
02 Output 6	24 X Latch/Input 1
03 Output 8	25 PWM/MCMTD X
04 Output 5	26 X Home
05 Output 2	27 Y Home
06 Abort (see Appendix A)	28 Z Home
07 Input 6	29 W Home
08 Z Latch/Input 3	30 Error Out
09 SIGN/AEN Y	31 PWM/MCMTD W
10 Output Compare	32 5V
11 Reverse Limit X	33 5V
12 Reverse Limit Y	34 Ground
13 Reverse Limit Z	35 Ground
14 Reverse Limit W	36 Input 8
15 Forward Limit W	37 Input 5
16 SIGN/AEN W	38 Y Latch/Input 2
17 SIGN/AEN Z	39 PWM/MCMTD Y
18 Output 7	40 SIGN/AENX
19 Output 4	41 Forward Limit X
20 Output 1	42 Forward Limit Y
21 Output 3	43 Forward Limit Z
22 Input 7	44 Reset

J1 Power (8-pin)
1 Earth
2 +VDC (18V-60V)
3 +VDC (18V-60V)
4 +VDC (18V-60V)
5 GND
6 GND
7 GND
8 GND

Mating Connectors

	Connector	Terminal Pins
J1: DC Power Connector	8-pin Mini Universal MATE-N-LOK AMP# 770579-1	AMP# 170361-1
JX1, JY1, JZ1, and JW1: 4-pin Motor Lead Connector	4-pin Mini Universal MATE-N-LOK AMP# 172167-1	AMP# 170361-1

Operation

Brushless Motor Setup

Note: If you purchased a Galil motor with the amplifier, it is ready for use. No additional setup is necessary.

To begin the setup of a brushless motor, it is first necessary to have communications with the motion controller. Refer to the user manual supplied with your controller for questions regarding controller communications. Connect the encoders and motor leads to the amplifier, then configure the controller and amplifier in software. This first involves taking all appropriate safety precautions. For example, set a small error limit ($ER^*=1000$), a low torque limit ($TL^*=3$), and set off on Error to 1 for all axes ($OE^*=1$). Review the command reference and controller user manual for further details. Now it is safe to power the amplifier.

The controller has been programmed to test whether the Hall commutation order is correct. To test the commutation for the X axis, issue the BS command. The default for the BS command is $BSn=0.25,1000$ which will send 0.25 volts to the amplifier for 1 second. $BSX=0.5,300$ will issue 0.5 volts from the controller for 300 milliseconds on the X axis. It may be necessary to issue more voltage to create motion. The controller will attempt to move the motor through one revolution. If the motor is unable to move, hall transitions are not correct, or the feedback polarity is reversed, the controller will return suggestion to the terminal response window regarding the problem and solution. After making any necessary changes to the motor phase wiring, confirm correct operation by re-issuing the BS command. Once the axis is wired correctly, the controller is ready to perform closed-loop motion.

Brushless Amplifier Software Setup

Select the amplifier gain that is appropriate for the motor. The amplifier gain command (AG) can be set to 0, 1, or 2 corresponding to 0.1, 0.25, and 0.5 A/V. In addition to the gain, peak and continuous torque limits can be set through TK and TL respectively. The TK and TL values are entered in volts per axis. The peak limit will set the maximum voltage that will be output from the controller to the amplifier. The continuous current will set what the maximum average current is over a one second interval. As an example, if the gain is set to 0.5 A/V with a torque limit of 3 ($TLn=3$) this will allow the amplifier to output no more than 1.5 amps of current on the specified axis.

The user can choose between Inverter (AU0 or AU1) or Chopper mode (AU0.5 or AU1.5). For motors with inductance between 200 and 500 μ H, use Chopper mode, for motors with inductance greater than 500 mH, use inverter mode. Note that chopper mode inherently has the potential to cause instability at rest depending on tuning and axis characteristics. The user can also select between normal (AU0 or AU0.5) or high current bandwidth (AU1 or AU1.5). As an example of the AU command, if the X axis uses normal current loop bandwidth and chopper mode, and the Y axis uses high current loop bandwidth and inverter mode, the setting would be AU 0.5,1.

The bandwidth of the current loop for a specific combination can be determined by the AW command with the basic amplifier parameters. To calculate the bandwidth for the X axis, issue $AWX=v,l,n$ where v represents the DC voltage input to the card, l represents the inductance of the motor in millihenries, and n represents the AU setting.

Note: For most applications, unless the motor has more than 5 mH of inductance with a 24V supply, or 10 mH of inductance with a 48 V supply, the normal current loop bandwidth option should be chosen. AW will return the current loop bandwidth in Hertz.

Brush Amplifier Operation

The AMP-20542 also allows brush servo operation. To configure an axis for brush-type operation, connect the 2 motor leads to Phase A and Phase B connections for the axis. Connect the encoders, homes, and limits as required. Set the controller into brush-axis operation by issuing the BR command (BRn,n,n,n). By setting n=1, the controller will operate in brush mode on that axis. For example, BR0,1,0,0 sets the Y-axis as brush-type, all others as brushless. If an axis is set to brush-type, the amplifier has no need for the Hall inputs. These inputs can subsequently be used as general-use inputs, queried with the QH command. The gain settings for the amplifier are identical to the brushless operation.

Using External Amplifiers

The AMP-20542 breaks out the step/direction or amplifier enable/motor command signals to control an external servo or stepper amplifier. For example, a machine might have two axes (XY) that use the AMP-20542, one axis that uses an external stepper amplifier (Z), and another that uses an external servo amplifier (W). The pulse and direction signals for an external step drive are accessed through the high density 44-pin D-sub connector, as are the amplifier enable and motor command line for an external servo amplifier. To configure which signals are brought out, jumpers are used between connectors J3 and J4 (see figure below). If no jumpers are installed (factory default), the corresponding pins on the 44-pin connector will be unconnected. In the following example, the W axis will output the motor command on pin 31 and amplifier enable on pin 16. The Z axis will output PWM (Step) on pin 1 and Sign (Direction) on pin 17 of the 44-pin connector.

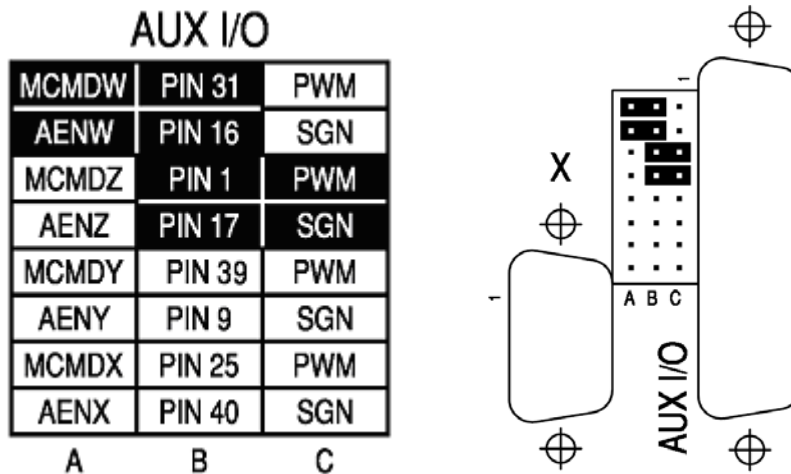

Figure 31 The W-axis is configured for an external servo amplifier and Z for an external stepper amplifier

Error Monitoring and Protection

The amplifier is protected against over-voltage, under-voltage, and over-current for brush and brushless operation. The controller will also monitor for illegal Hall states (000 or 111 with 120° phasing). The controller will monitor the error conditions and respond as programmed in the application. The errors are monitored via the TA command. TA n may be used to monitor the errors with n = 0, 1, 2, or 3. The command will return an eight bit number representing specific conditions. TA0 will return errors with regard to under voltage, over voltage, and over current. TA1 will return hall errors on the appropriate axes, TA2 will monitor if the amplifier

current exceeds the continuous setting, and TA3 will return if the ELO has occurred as a result of a hard abort input.

The user also has the option to include the special label #AMPERR in their program to handle amplifier errors. As long as a program is executing in thread zero, and the #AMPERR label is included, the program will jump to the label and execute the user-defined routine when an error is detected. Note that the TA command is a monitoring function only, and does not generate an error condition. The over voltage condition will not permanently shut down the amplifier or trigger the #AMPERR routine. The amplifier will only be momentarily disabled and when the condition goes away the amplifier will continue normal operation assuming the position error has not exceed the error limit.

Hall Error Protection

During normal operation, the controller should not have any Hall errors. Hall errors can be caused by a faulty Hall-effect sensor or a noisy environment. If at any time the Halls are in an invalid state, the appropriate bit of TA1 will be set. The state of the Hall inputs can also be monitored through the QH command. Hall errors will cause the amplifier to be disabled if OE 1 is set, and will cause the controller to enter the #AMPERR subroutine if it is included in a running program.

Under-Voltage Protection

If the supply to the amplifier drops below 8 VDC, the amplifier will be disabled. The amplifier will return to normal operation once the supply is raised above the 12V threshold. Bit 3 of the error status (TA0) will tell the user whether the supply is in the acceptable range.

Over-Voltage Protection

If the supply to the amplifier rises above 68 VDC, then the amplifier will automatically disable. The amplifier will re-enable when the supply drops below 66 V. This error is monitored with bit 1 of the TA0 command. This protection is configurable to activate at 34V and re-enable at 33V by placing a jumper onto JP10.

Over-Current Protection

The amplifier also has circuitry to protect against over-current. If the total current from the supply exceeds 20A, the amplifier will be disabled. The amplifier will not be re-enabled until the SH command has been sent or the controller is reset. Since the AMP-20542 is a trans-conductance amplifier, the amplifier will never go into this mode during normal operation. The amplifier will be shut down regardless of the setting of OE, or the presence of the #AMPERR routine. Bit 0 of TA0 will be set.

Note: If this fault occurs, it is indicative of a problem at the system level. An over-current fault is usually due to a short across the motor leads or a short from a motor lead to ground.

Abort Input Options

See Appendix A.

Chapter 11 SDM-20640/20620

Introduction

The SDM-20640 microstepper module drives four bipolar two-phase stepper motors with 1/64 microstep resolution (the SDM-20620 drives two). The current is selectable with options of 0.5, 1.0, 2.0, & 3.0 Amps per axis. Like the DB-28040, the SDM-206x0 family provides for the addition of 8 analog input to the DMC-21x3. The analog inputs accept +/- 10 V input and have a resolution of 12 bits; a 16 bit option is available. **MT-2 MUST BE SET WHEN USING THE SDM-206X0.**

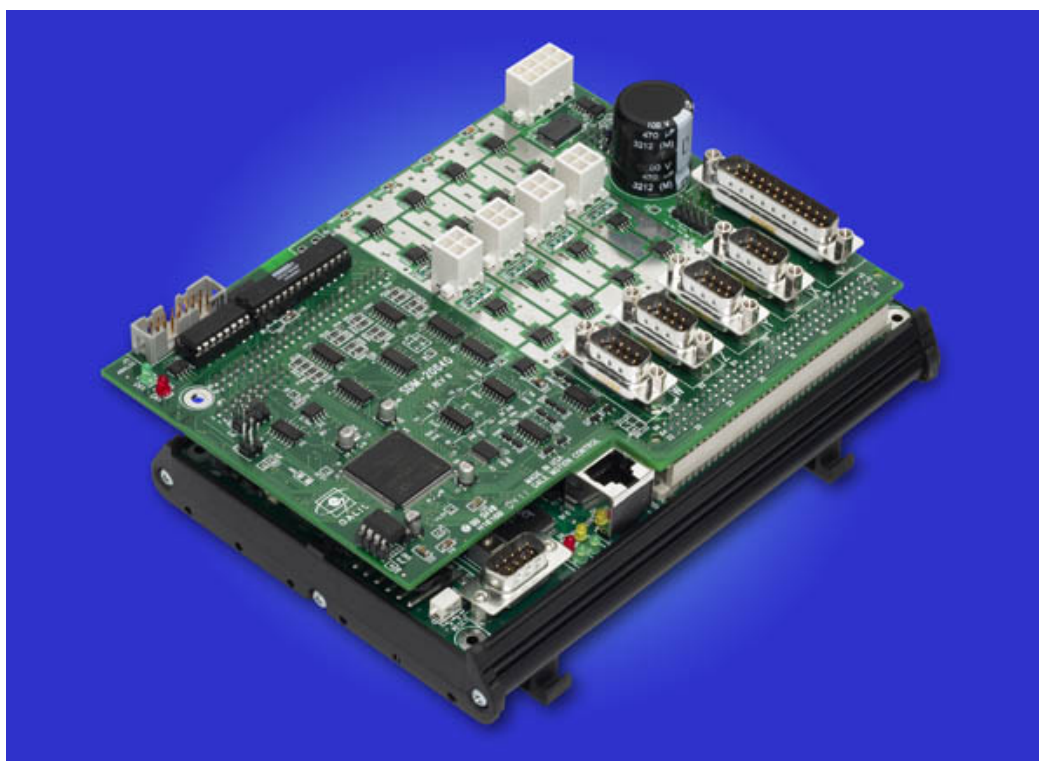

Figure 32 SDM-20640 shown mounted to a DMC-2143-DIN

Electrical Specifications

DC Supply Voltage:	12-60 VDC
Max Drive Current (per axis)	3.0 Amps (selectable with AG command)
Max Step Frequency	3 MHz (microsteps)
Motor Type	Bipolar two-phase
Switching Frequency	60 kHz
Minimum Load Inductance:	0.5 mH

Layout

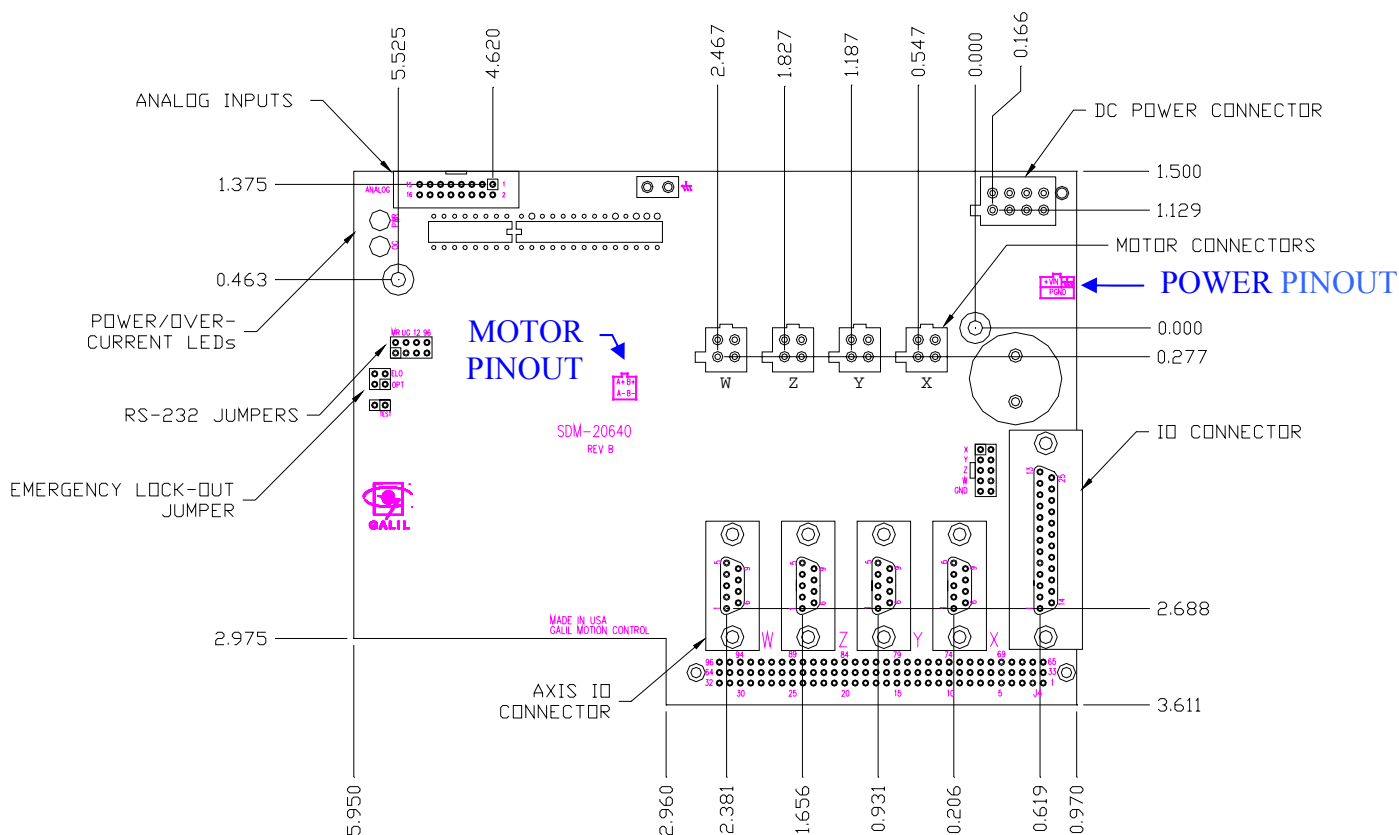

Figure 33 SDM-20640 Dimensions
Overall Dimensions: 6.92" x 5.11"

Pinout

JX1 Motor Output X (4pin Molex)
1 XMOB+
2 XMOA+
3 XMOB-
4 XMOA-

JY1 Motor Output Y (4pin Molex)
1 YMOB+
2 YMOA+
3 YMOB-
4 YMOA-

JZ1 Motor Output Z (4pin Molex)
1 ZMOB+
2 ZMOA+
3 ZMOB-
4 ZMOA-

JW1 Motor Output W (4pin Molex)
1 WMOB+
2 WMOA+
3 WMOB-
4 WMOA-

JX2 X-axis (9 pin Male D-sub)	
1	Forward limit X
2	Home X
3	5V
4	MA- X
5	MB- X
6	Reverse limit X
7	Ground
8	MA+ X
9	MB+ X

JY2 Y-axis (9 pin Male D-sub)	
1	Forward limit Y
2	Home Y
3	5V
4	MA- Y
5	MB- Y
6	Reverse limit Y
7	Ground
8	MA+ Y
9	MB+ Y

JZ2 Z-axis (9 pin Male D-sub)	
1	Forward limit Z
2	Home Z
3	5V
4	MA- Z
5	MB- Z
6	Reverse limit Z
7	Ground
8	MA+ Z
9	MB+ Z

JW2 W-axis (9 pin Male D-sub)	
1	Forward limit W
2	Home W
3	5V
4	MA- W
5	MB- W
6	Reverse limit W
7	Ground
8	MA+ W
9	MB+ W

J3 I/O (25 pin Male D-sub)	
1	Ground
2	Latch X/Input 1
3	Latch Z/Input 3
4	Input 5
5	Input 7
6	Abort (see Appendix A)
7	Output 1
8	Output 3
9	Output 5
10	Output 7
11	Ground
12	Reset

13	NC
14	5V
15	Latch Y/Input 2
16	Latch W/Input 4
17	Input 6
18	Input 8
19	Encoder – Compare Output
20	Output 2
21	Output 4
22	Output 6
23	Output 8
24	5V
25	Error Out

J1 Power (8 Pin Molex)			
1	Earth Ground	5	Ground
2	+V (12V-60V)	6	Ground
3	+V (12V-60V)	7	Ground
4	+V (12V-60V)	8	Ground

J11 Analog (16 Pin IDC Header)			
1 Ground	5 Analog In 3	9 Analog In 7	13 -12V
2 Ground	6 Analog In 4	10 Analog In 8	14 +12V
3 Analog In 1	7 Analog In 5	11 Ground	15 +5V
4 Analog In 2	8 Analog In 6	12 Ground	16 Ground

JP8 External Drive Breakout (10 Pin IDC Header)	
1 X Amp Enable	2 X Motor Command
3 Y Amp Enable	4 Y Motor Command
5 Z Amp Enable	6 Z Motor Command
7 W Amp Enable	8 W Motor Command
9 Ground	10 Ground

Mating Connectors

	Connector	Terminal Pins
J1: DC Power Connector	8-pin Mini Universal MATE-N-LOK AMP# 770579-1	AMP# 170361-1
JX1, JY1, JZ1, and JW1: 4 pin Motor Lead Connector	4-pin Mini Universal MATE-N-LOK AMP# 172167-1	AMP# 170361-1

Configurations for SDM-206x0

The AG command sets the current on each axis and the LC command configures each axis's behavior when holding position. These commands are detailed below:

Current Level Setup (AG Command)

AG configures how much current the SDM-206x0 delivers to each motor. Four options are available: 0.5A, 1.0A, 2.0A, and 3.0Amps (**Note:** when using the 3.0A setting, a cooling fan or adequate air flow is recommended).

Drive Current Selection per Axis: AG n,n,n,n,n,n,n

- n = 0 0.5 A
- n = 1 1 A (default)
- n = 2 2 A
- n = 3 3.0 A

Low Current Setting (LC Command)

LC configures each motor's behavior when holding position (when RP is constant) and has three possible configurations:

- LC command set to 0 "Full Current Mode" - causes motor to use 100% of peak current (AG) while at a "resting" state (profiler is not commanding motion). This is the default setting.
- LC command set to 1 "Low Current Mode" - causes motor to use 25% of peak current while at a "resting" state. This is the recommended configuration to minimize heat generation and power consumption.
- LC command set to 2 causes motor to use zero current while at a "resting" state. This setting is for a motor-off condition at rest.

Percentage of full (AG) current used while holding position with LC n,n,n,n,n,n,n

n = 0	100%
n = 1	25%
n = 2	0%

The LC command must be entered after the motor type has been selected for stepper motor operation (i.e. MT-2,-2,-2,-2). LC is axis-specific, thus LC1 will cause only the X-axis to operate in "Low Current" mode.

Abort Input Options

See Appendix A.

THIS PAGE LEFT BLANK INTENTIONALLY

Chapter 12 PCM-20900

Introduction

The PCM-20900 is a module that can be used to facilitate the design of a custom daughter board. The module contains the 96 pin connector allowing it to connect to the DMC-21x3. The user can then test the operation of circuitry before committing to a daughter board design. If you need more information for designing your own daughter board, please refer to application note #1232 (<http://www.galilmc.com/support/appnotes/econo/note1232.pdf>).

Please also note that if for some reason, the standard daughter boards do not provide the required options, you may contact Galil for pricing regarding Galil designed custom daughter boards.

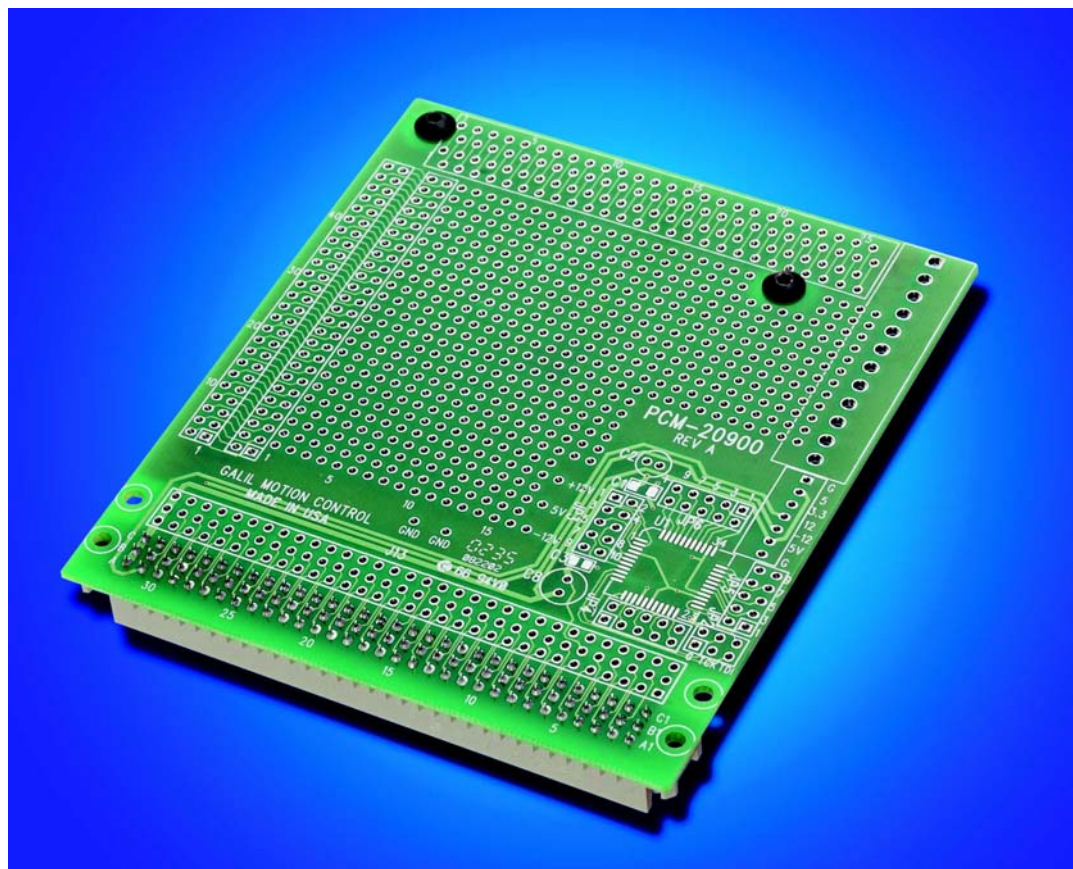

Figure 34 PCM-20900

THIS PAGE LEFT BLANK INTENTIONALLY

Chapter 13 DB-28040

Introduction

The DB-28040 is an I/O daughter board for the DMC-21x2/21x3 series motion controllers.

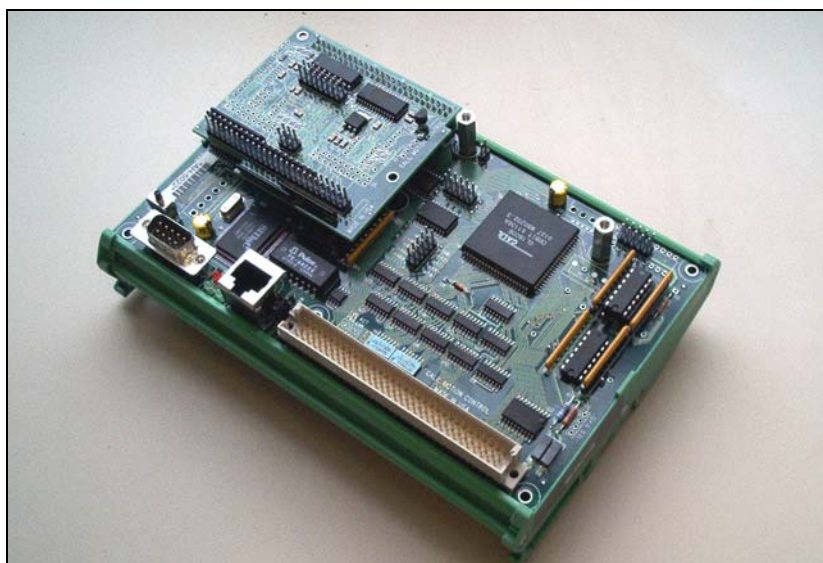

Figure 35 DB-28040 Mounted to DMC-2143-DIN

Electrical Specifications

Standard configuration allows for 8 (± 10 VDC) analog inputs and 40 programmable digital IO (3.3V logic). The DB-28040-5V option provides up to 24 Open-collector outputs that can sink to 5 Volts (3mA). In the -5V configuration, the first 3 banks of 8 bits may be configured as outputs. There is no limitation on the placement of inputs. The following tables illustrate the various Input/Output combinations:

DB-28040 Valid I/O	
Inputs	Outputs
40	0
32	8
24	16
16	24
8	32
0	40

DB-28040-5V Valid I/O	
Inputs	*Outputs
40	0
32	8
24	16
16	24

*Note: Only the first three I/O banks may be configured as outputs

Layout

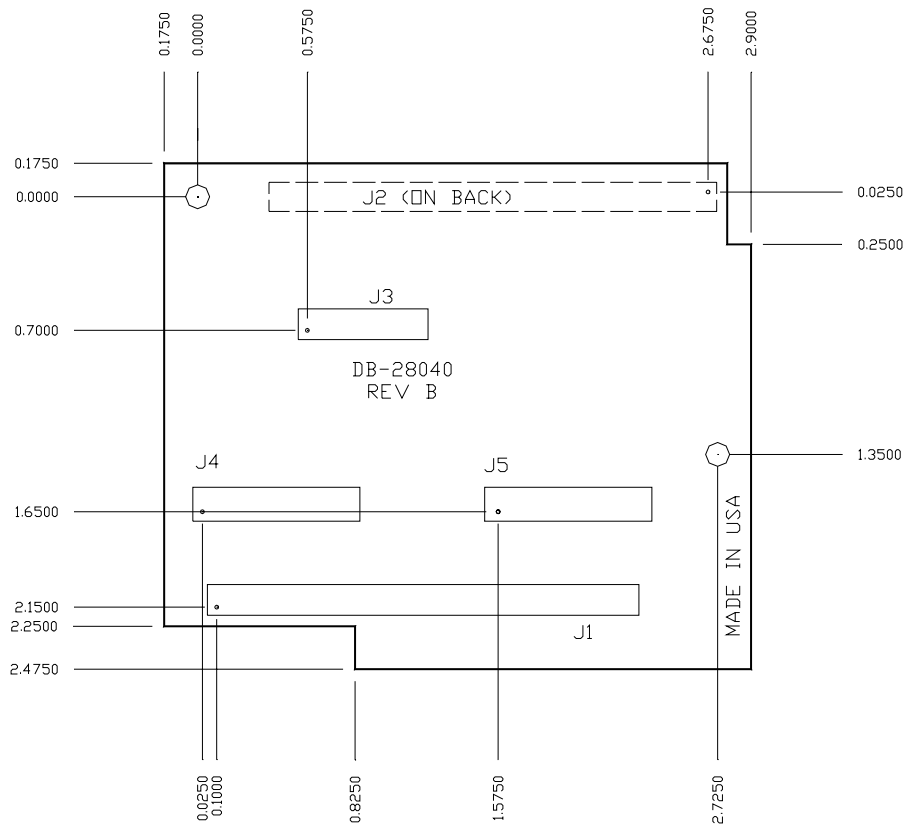

Figure 36 DB-28040 Interconnect Mounting Dimensions
Overall Dimensions: 3.075" x 2.650"

Pinout

J1 – 40 Digital I/O (50-Pin IDC Header)	
1 Bank 4 – Bit 40	2 Bank 5 – Bit 41
3 Bank 4 – Bit 39	4 Bank 5 – Bit 42
5 Bank 4 – Bit 38	6 Bank 5 – Bit 43
7 Bank 4 – Bit 37	8 Bank 5 – Bit 44
9 Bank 4 – Bit 36	10 Bank 5 – Bit 45
11 Bank 4 – Bit 35	12 Bank 5 – Bit 46
13 Bank 4 – Bit 34	14 Bank 5 – Bit 47
15 Bank 4 – Bit 33	16 Bank 5 – Bit 48
17 Bank 3 – Bit 32	18 Bank 6 – Bit 49
19 Bank 3 – Bit 31	20 Bank 6 – Bit 50
21 Bank 3 – Bit 30	22 Bank 6 – Bit 51
23 Bank 3 – Bit 29	24 Bank 6 – Bit 52
25 Bank 3 – Bit 28	26 Bank 6 – Bit 53
27 Bank 3 – Bit 27	28 Bank 6 – Bit 54
29 Bank 3 – Bit 26	30 Bank 6 – Bit 55
31 Bank 3 – Bit 25	32 Bank 6 – Bit 56
33 Bank 2 – Bit 24	34 GND
35 Bank 2 – Bit 23	36 GND
37 Bank 2 – Bit 22	38 GND
39 Bank 2 – Bit 21	40 GND
41 Bank 2 – Bit 20	42 GND
43 Bank 2 – Bit 19	44 GND
45 Bank 2 – Bit 18	46 GND
47 Bank 2 – Bit 17	48 GND
49 5 V	50 GND

J3 – 8 Analog Inputs (16-Pin IDC Header)	
1 GND	2 GND
3 Analog Input 1	4 Analog Input 2
5 Analog Input 3	6 Analog Input 4
7 Analog Input 5	8 Analog Input 6
9 Analog Input 7	10 Analog Input 8
11 GND	12 GND
13 -12 Volt Supply	14 +12 Volt Supply
15 5 V	16 GND

Interfacing to the Digital I/O

The DB-28040-5V offers 40 digital I/O points that can interface directly to Grayhill and OPTO-22 I/O mounting racks. These I/O points can be configured as inputs or outputs in 8 bit increments with the CO command. The I/O points accessed from the J2 header of the DB-28040-5V are connected directly to the I/O rack using a 50-pin IDC ribbon connector.

Note: special considerations must be made to avoid damage when using Opto-22 G4 series racks, read application note# 5450 for details:
(<http://www.galilmc.com/support/appnotes/miscellaneous/note5450.pdf>)

16 bit Analog Inputs

The DB-28040 comes with 12-bit Analog Inputs standard. For 16-bit Analog Inputs, order the DB-28040-16. When using the AF command with the -16 version, the DMC-21x3 controller requires the 16-bit Analog Feedback firmware. The voltage input range is -10V – +10V.

To ensure they function properly, don't apply a voltage to the analog inputs until after the controller is powered. If possible, it is recommended that circuit generating the analog signal be powered by the +5 or ±12V sources available on the controller. This will ensure that the input voltage is not applied too soon.

SSI

The DB-28040 can also be ordered to support SSI encoders.

When using the SSI option for the DB-28040, note that bank 6 (bits 49 to 56) are not active. Please see Application Note 2438: Galil SSI Encoder Interface, for more details.

DB-28040 and AMP-205x0

The standard DB-28040 is not compatible with an AMP-205x0; however, the DB-28040-RA can be ordered to have a special right angle connector installed so that it can connect while the AMP-205x0 is present. This option must be ordered at the time the AMP and DMC-21x3 is ordered because both the AMP and DB require modification. Order AMP-205x0-DBREADY. The eight analog inputs on the AMP become invalid in this configuration. Only the eight analog inputs on the DB may be used.

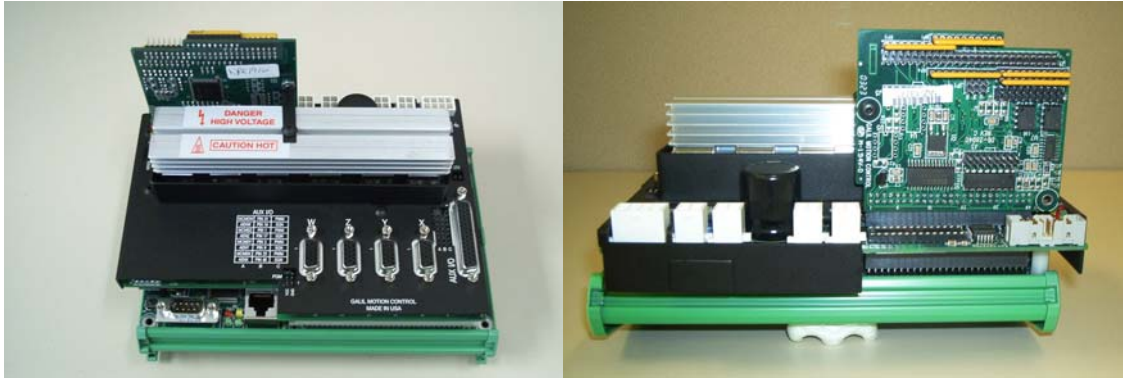

Figure 37 DMC-2143-DIN with AMP-20540 and DB-28040

DB-28040 and AMP-205x2 or SDM-20640

To use the AMP-205x2 or SDM-20640 with the DB-28040, order AMP-205x2-DBREADY or SDM-20640-DBREADY. The standard DB-28040 is used, and lays flat on top of the AMP or SDM, but the AMP or SDM requires modification. The eight analog inputs on the AMP become invalid in this configuration. Only the eight analog inputs on the DB may be used.

THIS PAGE LEFT BLANK INTENTIONALLY

Chapter 14 DB-28104

Introduction

A family of feedback devices, commonly called Sin/Cosine encoders or 1 Volt peak-peak encoders are becoming increasingly popular due to their cost, ease of use, and performance. Galil Motion Control has developed an interface board for the DMC-21x2/21x3 series motion controllers that give the engineer the ability to close the servo loop around these feedback devices. Figure 1 shows the DB-28104.

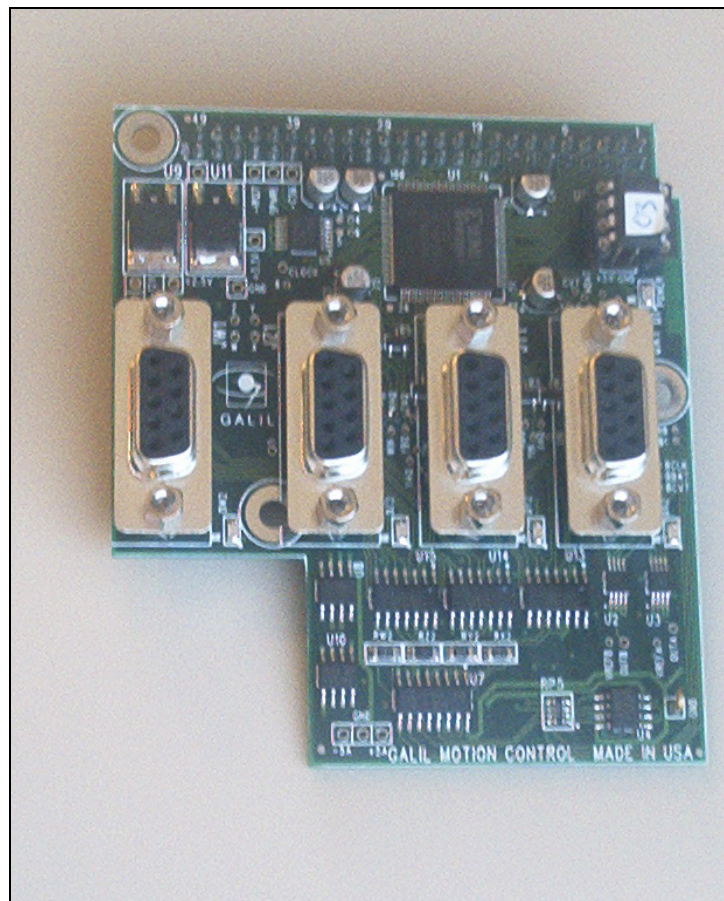

Figure 1- DB-28104

The DB-28104 can be used in conjunction with any of the Galil amplifier boards. In Figure 2, a DMC-2143 is mated to the DB-28104 and an ICM-20100 breakout module.

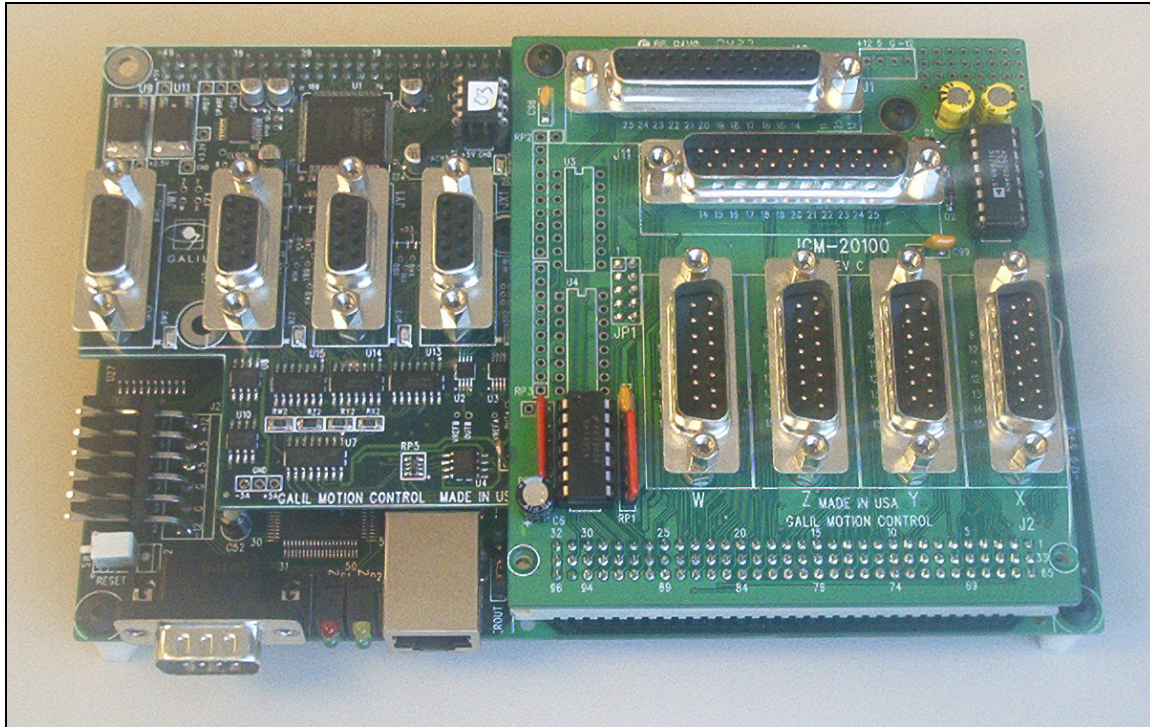

Figure 2- DMC-2143+ICM-20100+DB-28104

Theory of Operation

Traditional quadrature rotary encoders work by having two sets of lines inscribed radially around the circumference of an optical disk. A light is passed through each of these two sets of lines. On the other side of the gratings, photo sensors detect the presence (or absence) of these lines. These two sets of lines are offset from each other such that one leads the other by one quarter of a complete cycle as shown in Figure 3 below. These signals are commonly referred to as the Channels A and B. The direction of rotation of the encoder can be inferred by which of the A and B signals leads the other. Each rising or falling edge indicates one quadrature count. Thus for a complete cycle of the square wave there are a total of four encoder counts.

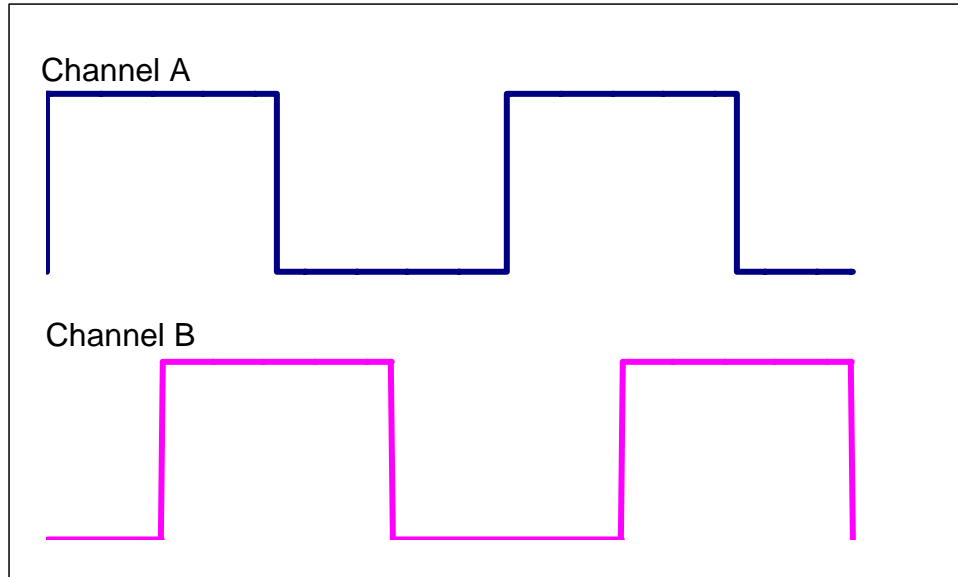

Figure 3: Quadrature Encoder Signals

A sinusoidal encoder is similar to a quadrature encoder in that it produces two signals that are read from two sets of lines inscribed on an optical disk. The difference is that the two signals are output as analog sinusoidal waves as shown in Figure 4.

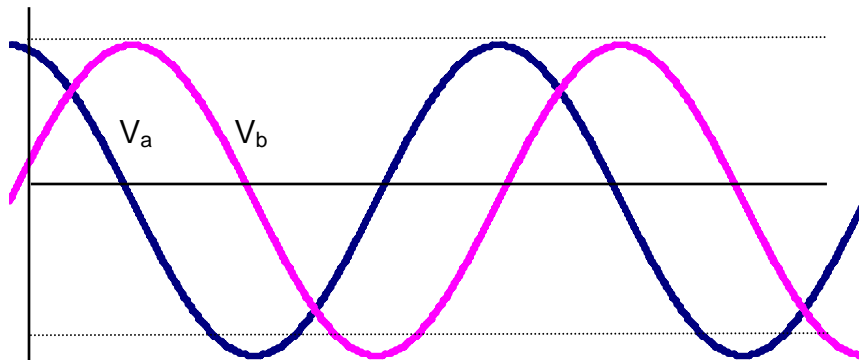

Figure 4: Sinusoidal Encoder Signals

When the motion controller is mated to the DB-28104, the position is tracked on two levels. First, the number of coarse cycles is counted much like is done with a quadrature encoder. On the fine level the precise position inside the cycle is determined from the two sinusoidal signals using bit-wise interpolation. This interpolation can be set by the user in the range of 2^5 through 2^{12} points per sinusoidal cycle.

The unique position within one cycle can be read using the following equation:

$$\text{Fine} = \frac{2^n}{360} \tan^{-1} \left(\frac{V_b}{V_a} \right)$$

The overall position can be determined using:

$$\text{Position} = \text{Coarse_cycles} \cdot 2^n + \text{Fine}$$

where:

n is the number of bits of resolution that were used in the conversion.

Coarse_cycles is the whole number of cycles counted.

Fine is the interpolated position within one cycle.

V_b and V_a are the two signals as indicated in Figure 4.

Setting up the Encoder

Each axis uses a 9-pin female connector. The pinout is described in Table 1.

JX1 X-Axis (9-pin Female D-sub)	
Pin	Description
1	5 Volt encoder power
2	Index -
3	MA-X
4	MB-X
5	NC
6	Ground
7	Index +
8	MA+X
9	MB+X

JZ1 Z-Axis (9-pin Female D-sub)	
Pin	Description
1	5 Volt encoder power
2	Index -
3	MA-Z
4	MB-Z
5	NC
6	Ground
7	Index +
8	MA+Z
9	MB+Z

JY1 Y-Axis (9-pin Female D-sub)	
Pin	Description
1	5 Volt encoder power
2	Index -
3	MA-Y
4	MB-Y
5	NC
6	Ground
7	Index +
8	MA+Y
9	MB+Y

JW1 W-Axis (9-pin Female D-sub)	
Pin	Description
1	5 Volt encoder power
2	Index -
3	MA-W
4	MB-W
5	NC
6	Ground
7	Index +
8	MA+W
9	MB+W

Table 1- Encoder Pinouts

After wiring the encoders, it is recommended that the system is powered up with the Motor Off jumper installed, or the power to the amplifiers disabled. Connect to the controller using DMCSmartTerminal or other compatible software. Sinusoidal encoder interpolation mode is selected using the AF command:

AFm

where m=0 uses the default quadrature encoder.

m=1 for standard Analog Feedback (DB-28040 or AMP-20540 or SDM-20640 required)

m=5 to 12 indicates that the sinusoidal encoder input is to be used with 2^m interpolation counts per encoder cycle. (The DB-28104 is required.)

For example, if the encoder cycle is 40 microns, AF10 results in $2^{10}=1024$ counts per cycle, or a resolution of 39 nanometers per count. Figure 5 shows a screen capture.

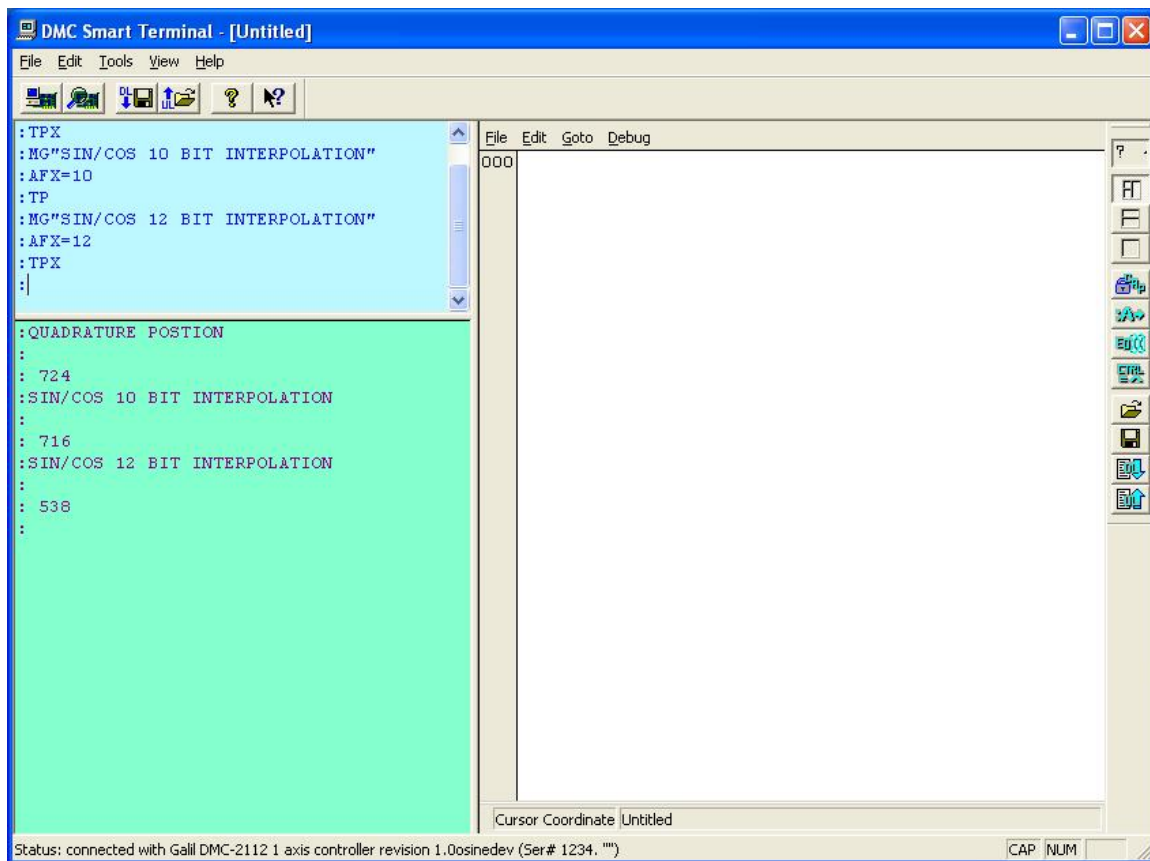

Figure 5- Setting AF command.

Once the encoder is shown to provide acceptable feedback with correct polarity, set a low torque limit (TL). Set a reasonable Error Limit (ER) and enable the Off-on-Error function (OE). This ensures that the axis will not be driven unstable once power is applied to the motors.

Once an axis is controlled using a sinusoidal encoder, the maximum allowable speed to 50,000,000 counts/sec and acceleration/deceleration settings are increased to 10^9 counts/s².

If the axis is controlled in a coordinated move with the VM or LM mode, the parameters of the coordinated move, VA, VD or VS are also increased to the expanded values. However, it is the responsibility of the user to assure that the speeds on the other axes involved in the coordinated move, if not in sinusoidal encoder mode, remain within the 12,000,000 counts/s limit.

Tuning the System

With high-resolution feedback, it is very common for the controller to require tuning gains that are numerically low. If the tuning gains are very low, consider using an amplifier that has lower gain. It is almost certain that manual tuning will be required. Set up a 'typical' move, and capture the position data with the WSDK oscilloscope function. For this example, the X axis was set up with the following program:

```
#SETUP
AFX=10;'SET SINE ENCODER TO 10 BIT INTERPOLATION
SPX=1000000;'X AXIS SLEW TO 1m COUNTS/SEC
ACX=1000000;DCX=1000000;'SET ACCEL AND DECEL
#MOVE
PRX=1000;' MOVE X AXIS FWD 1000 COUNTS
BGX;AMX;'BEGIN MOTION AND WAIT FOR COMPLETE
WT500;'WAIT 500 SAMPLES
PRX=0;'MOVE X AXIS TO POSITION ZERO
BGX;AMX;'BEGIN MOTION AND WAIT FOR COMPLETE
WT500;'WAIT 500 SAMPLES
JP#MOVE;' LOOP
```

After extensive manual tuning, the following parameters were determined:

```
KDX = 22.5
KPX = 6.13
KIX= 4.3
ILX= 9
ITX= 0
FAX= 0
FVX= 1
PLX= 0
```

This set of tuning parameters resulted in a step response shown in Figure 6.

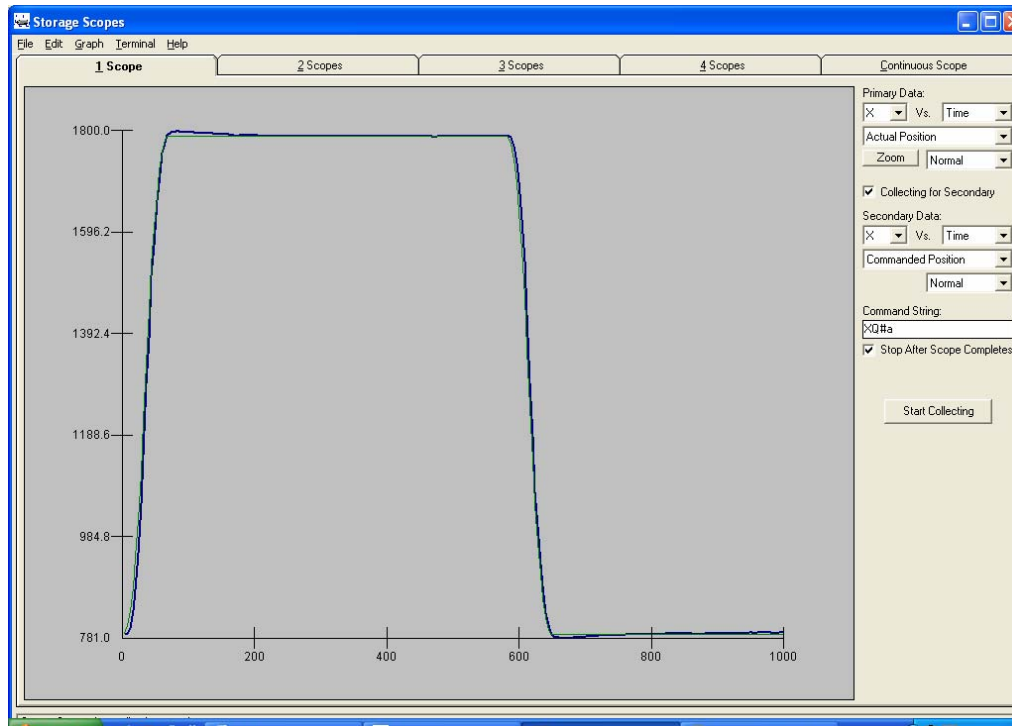

Figure 6- AFX=10 Step Response

Close inspection of the step response shows that some overshoot occurred. However, any attempt to eliminate this overshoot resulted in an overdamped system.

A second test was run with AFX=12. This highest interpolation requires that the system be wired in such a way that noise is nearly eliminated. Even one or two bits of noise on the analog signals can result in large disturbances in the position calculation. The same system with AFX=12 resulted in the following gains:

KDX = 4.75
 KPX = 2.0
 KIX= 2.1
 ILX= 9
 ITX= 0
 FAX= 0
 FVX= 0
 PLX= .2

Figure 7 shows the associated step response.

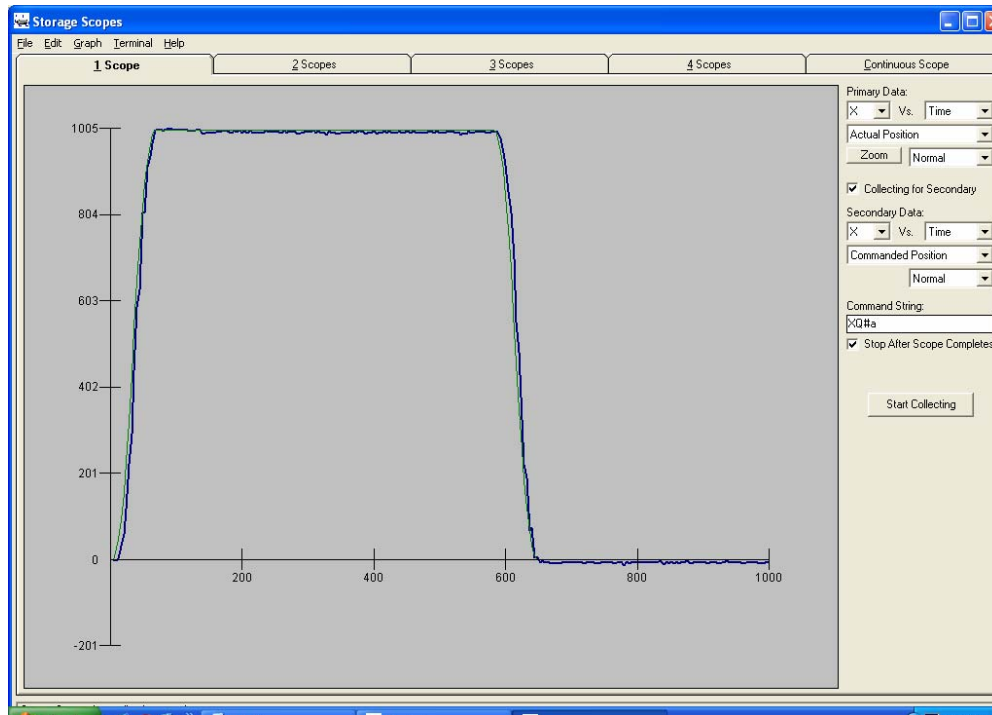

Figure 7- AFX=12 step response.

Example sin/cos Encoders

RSF Elektronik MSA 670.3

20 μm pitch

at AFX=12 results in 5 nm position resolution.

* This encoder can be ordered from RSF with a cable that mates directly to the DB-28104.

Use cable code UIE.

www.rsf.net



Renishaw RGH41B30F00A

40 μm pitch

at AFX=10 result in 40 nm position resolution



Renishaw RGH22B series

20 μm pitch

at AFX=12 result in 5 nm position resolution

www.renishaw.com/client/category/UKEnglish/CAT-1079.shtml

Appendix A- DB-28104 Dimensions

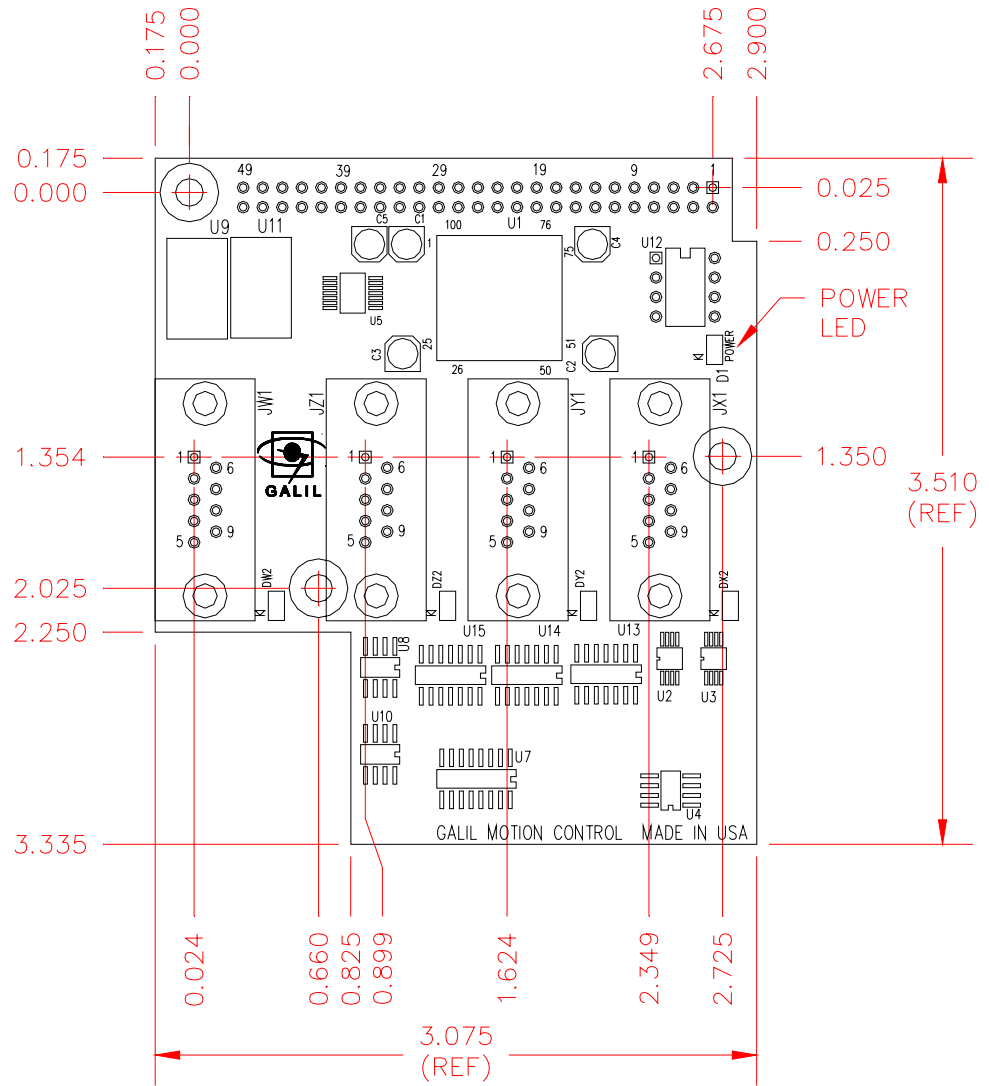

THIS PAGE LEFT BLANK INTENTIONALLY

Chapter 15 Cables for AMP-205x0, 20542 and 204x0

The **Cable-44pin-xm** is used to break-out the I/O signals on connector J3 of the AMP-205x0 or AMP-20542. This cable consists of a 44-pin High Density Male DSub connector at one end, and flying leads at the other end. This cable is available in 1 meter or 2 meter lengths, designated by the 'xm' portion of the part number. For example, the part number for the 2 meter length is **Cable-44pin-2m**.

There are three versions of the Cable-44, each version has different pinout color coding. The following describes the three versions and their differences.

Version 1: Cables purchased before January 2004 have a slick black sheath. The part number on the sheath is 0006-0044 REV.-S1.



Fig 1. Version 1 Cable-44 Part Number

For pinout information of this cable, see Table 1 below.

Note: This chapter refers only to the pinout of the AMP-205x0 and 20542. For the AMP-204x0, refer to Chapter 7.

Table 1. First Version of Cable-44, Pinout Color-Code

Pin	Description	Cable Color (Dot)	Pin	Description	Cable Color (Dot)
1	NC/PWMZ/Motor Command Z ¹	White	23	Input4/LatchW	Dark Blue
2	Output 6	White(Black)	24	Input1/LatchX	Dark Blue(White)
3	Output 8	Black	25	NC/PWMX/Motor Command X ¹	Dark Blue(Black)
4	Output 5	Black(White)	26	HOMEX	Dark Blue(Brown)
5	Output 2	Brown	27	HOMEY	Purple
6	Abort	Brown(White)	28	HOMEZ	Purple(White)
7	Input 6	Red	29	HOMEW	Silver
8	Input3/LatchZ	Red(White)	30	Error	Silver(White)
9	NC/SignY/AmpenY ¹	Red(Black)	31	NC/PWMW/Motor Command W ¹	White(Brown)
10	CMP	Red(Purple)	32	+5V	White(Orange)
11	RLSX	Orange	33	+5V	White(Yellow)
12	RLSY	Orange(White)	34	GND	White(Green)
13	RLSZ	Orange(Black)	35	GND	White(Blue)
14	RLSW	Orange(Purple)	36	Input8	White(Purple)
15	FLSW	Yellow	37	Input5	Pink
16	NC/SignW/AmpenW ¹	Yellow(White)	38	Input2/LatchY	Pink(White)
17	NC/SignZ/AmpenZ ¹	Yellow(Black)	39	NC/PWMY/Motor Command Y ¹	Pink(Black)
18	Output1	Yellow(Purple)	40	NC/SignX/AmpenX ¹	Pink(Brown)
19	Output4	Green	41	FLSX	Light Blue
20	Output1	Green(White)	42	FLSY	Light Blue(White)
21	Output3	Green(Black)	43	FLSZ	Light Blue(Black)
22	Input7	Green(Purple)	44	Reset	Light Blue(Brown)

¹ Refer to specific amplifier pinout information in the DMC-21x3 Accessories Manual.

Version 2: Cables purchased between January 2004 and March 2006 a black braided sleeve over the slick black sheath. The part number on the braided sleeve is 0006-0044 REV.-S1 (same as Version 1).



Fig 2. Version 2 Cable-44 Part Number

For pinout information of this cable, see Table 2 below.

Table 2. Second Version of Cable-44, Pinout Color-Code

Pin	Description	Cable Color(Stripe)	Pin	Description	Cable Color (Stripe)
1	NC/PWMZ/Motor Command Z ¹	Black	23	Input4/LatchW	Dark Blue(Black)
2	Output 6	Black(White)	24	Input1/LatchX	Dark Blue(Brown)
3	Output 8	Brown	25	NC/PWMX/Motor Command X ¹	Purple
4	Output 5	Brown (White)	26	HOMEX	Purple(White)
5	Output 2	Red	27	HOMEY	Light Blue
6	Abort	Red(White)	28	HOMEZ	Light Blue(White)
7	Input 6	Red(Black)	29	HOMEW	Light Blue(Black)
8	Input3/LatchZ	Red(Purple)	30	Error	Light Blue(Brown)
9	NC/SignY/AmpenY ¹	Orange	31	NC/PWMW/Motor Command W ¹	Silver
10	CMP	Orange(White)	32	+5V	Silver(White)
11	RLSX	Orange(Black)	33	+5V	Pink
12	RLSY	Orange(Purple)	34	GND	Pink(White)
13	RLSZ	Yellow	35	GND	Pink(Black)
14	RLSW	Yellow(White)	36	Input8	Pink(Purple)
15	FLSW	Yellow(Black)	37	Input5	White
16	NC/SignW/AmpenW ¹	Yellow(Brown)	38	Input2/LatchY	White(Black)
17	NC/SignZ/AmpenZ ¹	Green	39	NC/PWMY/Motor Command Y ¹	White(Brown)
18	Output7	Green(White)	40	NC/SignX/AmpenX ¹	White(Red)
19	Output4	Green(Black)	41	FLSX	White(Yellow)
20	Output1	Green(Purple)	42	FLSY	White(Green)
21	Output3	Dark Blue	43	FLSZ	White(Blue)
22	Input7	Dark Blue(White)	44	Reset	White(Purple)

¹ Refer to specific amplifier pinout information in the DMC-21x3 Accessories Manual.

Version 3: Cables purchased from March 2006 onward which are RoHS-compliant, have a slick black sheath(similar to Version 1). The part number on the sheath is 89140-03044 REV.-S1.

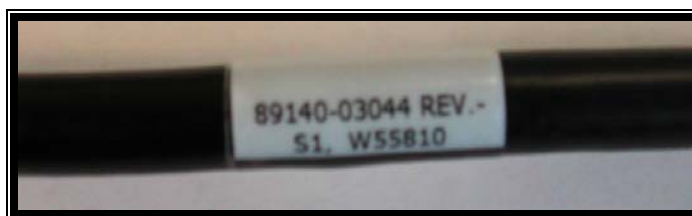

Fig 3. Version 3 Cable-44 Part Number

For pinout information of this cable, see Table 3 below.

Table 3. Third Version of Cable-44, Pinout Color-Code

Pin	Description	Cable Color (Stripe)	Pin	Description	Cable Color (Stripe)
1	NC/PWMZ/Motor Command Z ¹	Black	23	Input4/LatchW	Green(Black)
2	Output 6	Brown	24	Input1/LatchX	Gray(Black)
3	Output 8	Red	25	NC/PWMX/Motor Command X ¹	Pink(Black)
4	Output 5	Orange	26	HOMEX	Pink(Red)
5	Output 2	Yellow	27	HOMEY	Pink(Blue)
6	Abort	Green	28	HOMEZ	Pink(Green)
7	Input 6	Blue	29	HOMEW	Light Blue
8	Input3/LatchZ	Purple	30	Error	Light Blue(Black)
9	NC/SignY/AmpenY ¹	Gray	31	NC/PWMW/Motor Command W ¹	Light Blue(Red)
10	CMP	White	32	+5V	Light Blue(Blue)
11	RLSX	Pink	33	+5V	Light Blue(Green)
12	RLSY	Light Green	34	GND	Gray(Red)
13	RLSZ	Black(White)	35	GND	Gray(Green)
14	RLSW	Brown(White)	36	Input8	Purple(Black)
15	FLSW	Red(White)	37	Input5	Blue(Black)
16	NC/SignW/AmpenW ¹	Orange(White)	38	Input2/LatchY	Light Green(Black)
17	NC/SignZ/AmpenZ ¹	Green(White)	39	NC/PWMY/Motor Command Y ¹	Light Green(Red)
18	Output7	Blue(White)	40	NC/SignX/AmpenX ¹	Light Green(Blue)
19	Output4	Purple(White)	41	FLSX	Light Green(Green)
20	Output1	Red(Black)	42	FLSY	Light Yellow
21	Output3	Orange(Black)	43	FLSZ	Light Yellow(Black)
22	Input7	Yellow(Black)	44	Reset	Light Yellow(Red)

¹ Refer to specific amplifier pinout information in the DMC-21x3 Accessories Manual.

The **Cable-15pin-xm** is used to break-out the encoders and hall signals on connector J4, J5, J6, & J7 of the AMP-205x0 or AMP-20542. This cable consists of a 15-pin High Density Male DSub connector at one end, and flying leads at the other end. This cable is available in 1 meter or 2 meter lengths, designated by the 'xm' portion of the part number. For example, the part number for the 1 meter length is **Cable-15pin-1m**. This cable has a slick black sheath with part number 0006-0045 REV.A S1.

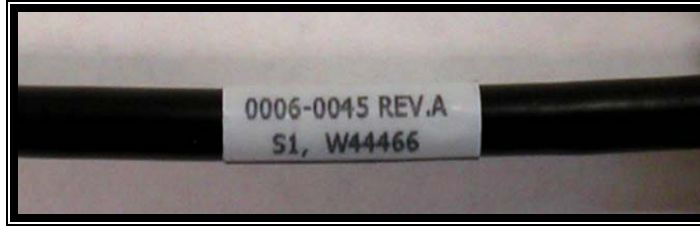

Fig 4. Cable-15 Part Number

For pinout color code information of this cable, see Table 4 below.

Table 4. Cable-15, Pinout Color-Code

Pin	Description	Cable Color (Stripe)	Pin	Description	Cable Color (Stripe)
1	Index +	Black	9	Aux A-	Green
2	Main B+	Black (White)	10	Hall U	Blue
3	Main A+	Brown	11	Aux A+	Purple
4	Aux B+	Brown (White)	12	Aux B-	Silver
5	GND	Red	13	Hall V	White
6	Index -	Red (White)	14	Hall W	Pink
7	Main B-	Orange	15	5V	Light Green
8	Main A-	Yellow			

THIS PAGE LEFT BLANK INTENTIONALLY

Appendix A Abort Input Options

The factory default behavior of a falling edge on the abort digital input causes the program to stop and all motors to servo to an instantaneous stop; however, it may be advantageous to configure the shut down of the amplifiers and/or keep the program running when this occurs.

CN Command: Program Control

The 5th field of the CN command configures how the program is handled when the abort line goes low on the controller. CN,,,0 is the default and causes program execution to halt. CN,,,1 will allow program to continue.

OE Command: Firmware Disable

If OE is set, the controller's firmware will toggle all amp enable lines to turn all drives off when an abort input occurs. The SH command needs to be issued to command further motion. If OE is not set, the controller will instantaneously servo all axis to a stop.

ELO Jumper: Hardware Disable (AMP-204x0, 205x0, SDM-206x0)

ELO (Emergency Lock Out) is a jumper setting on the AMP-204x0, AMP-205x0, and SDM-206x0 which configures the amplifier's behavior when the abort line goes low. With the jumper absent (default), the behavior of the motors is subject to the OE command above. If the jumper is installed, the amplifiers will be immediately shut down, leaving the axes in a free-spin state. Having the ELO jumper installed is similar to OE1, except that the amplifiers are disabled in hardware rather than firmware. WHEN ELO IS INSTALLED, OE SHOULD BE SET TO 1. To recover, issue MO; SH. When ELO is active, the overcurrent and overvoltage lights will turn on with the AMP-204x0 and AMP-205x0 (just the overcurrent light will blink on the SDM-206x0).

ELO Scenarios

The following tables show the response of the AMP-204x0, 205x0, and SDM-206x0 (with ELO jumper installed) to abort input and over current conditions.

DMC-2143 with AMP-20540

OE*=1; CN,,,1; #AMPERR defined

Condition input	LED state	Reaction	#AMPERR runs	TA	Recovery
Abort (J3 pin 6)	OC + OV	-disables axes A-D	yes	TA3 returns 1	MO;SH
A-D Over Current	OC	“	“	TA0 returns 1	“

DMC-2143 with SDM-20640

OE*=1; CN,,,1; #AMPERR defined

Condition input	LED state	Reaction	#AMPERR runs	TA	Recovery
Abort (J3 pin 6)	OC blinks	-disables axes A-D	yes	TA3 returns 1	MO;SH
A-D Over Current	OC	“	“	TA0 returns 1	“

DMC-2183 with two AMP-20440s

JP5: OC-IN7 (both AMP-20440s) RECOMMENDED

OE*=1; AE1,1; CN,,,,,1; #AMPERR defined

Condition input	LED state	Reaction	#AMPERR runs	TA0	Recovery
A-D Abort (J3 pin 6)	OC + OV axes A-D	-disables axes A-D -disables axes E-H*	yes	1	MO;SH
E-H Abort (J3 pin 6)	OC + OV axes E-H	-disables axes A-D* -disables axes E-H	“	“	“
A-D & E-H Abort	OC + OV axes A-D, E-H	-disables axes A-D -disables axes E-H	“	“	“
A-D Over Current	OC axes A-D	-disables axes A-D -disables axes E-H*	“	“	“
E-H Over Current	OC axes E-H	-disables axes A-D* -disables axes E-H	“	“	“

JP5: OC-ABRT (both AMP-20440s)

OE*=1

Condition input	LED state	Reaction	#AMPERR runs	TA0	Recovery
A-D Abort (J3 pin 6)	OC + OV axes A-D	-disables axes A-D -disables axes E-H*	NO	N/A	OE*=0;MO;SH; WT2;OE*=1
E-H Abort (J3 pin 6)	OC + OV axes E-H	-A-D motion continues -disables axes E-H	“	“	“
A-D & E-H Abort	OC + OV axes A-D, E-H	-disables axes A-D -disables axes E-H	“	“	“
A-D Over Current	OC axes A-D	-disables axes A-D -disables axes E-H*	“	“	“
E-H Over Current	OC axes E-H	-A-D motion continues -disables axes E-H	“	“	“

JP5: no jumper (both AMP-20440s)

OE*=1

Condition input	LED state	Reaction	#AMPERR runs	TA0	Recovery
A-D Abort (J3 pin 6)	OC + OV axes A-D	-disables axes A-D -disables axes E-H*	NO	N/A	MO;SH
E-H Abort (J3 pin 6)	OC + OV axes E-H	-A-D motion continues -disables axes E-H	“	“	“
A-D & E-H Abort	OC + OV axes A-D, E-H	-disables axes A-D -disables axes E-H	“	“	“
A-D Over Current	OC axis A-D	-disables axes A-D -E-H motion continues	“	“	“
E-H Over Current	OC axis E-H	-A-D motion continues -disables axes E-H	“	“	“

*firmware (OE1) disable (as opposed to hardware ELO disable)

Appendix B Mating D-Shells

The below table lists mating connector part numbers for all daughterboards. The gender is referenced to the mating connector.

Pins	Gender	Density	Daughterboards	Part Number
9	Female	low	SDM-20240, SDM-206x0	AMP 747905-2
15	Female	low	ICM-20100, ICM-20105, AMP-20340/1	AMP 747909-2
25	Female	low	ICM-20100, AMP-20240, AMP-20340/1, SDM-206x0	AMP 747913-2
25	Male	low	ICM-20100, ICM-20105	AMP 747912-2
37	Male	low	ICM-20105	AMP 747916-2
15	Male	high	AMP-204x0, AMP-205x0	Kycon K86-EA-15P
44	Male	high	AMP-204x0, AMP-205x0	Kycon K86-BA-44P

THIS PAGE LEFT BLANK INTENTIONALLY

Appendix C Command Reference

AE

FUNCTION: Amplifier Error.

DESCRIPTION:

The AE command is used in conjunction with an AMP-20440 or AMP-19540 to designate input 7 as the amp error status bit. A jumper must be placed on the amplifier to connect the amp error signal to the appropriate input. If enabled by AE1 and input 7 is activated, or if enabled by “AE,1” and input 15 is activated, bit 0 of TA will be set. If #AMPERR has been defined and an application program is executing, program execution will call the subroutine at the #AMPERR label.

ARGUMENTS:

 AE n,m where

n = 0 Disables input 7 as amp error status bit (Axes 1-4)
n = 1 Enables Input 7 as amp error status bit (Axes 1-4)
n = ? Returns the value of the amplifier error (Axes 1-4)

m = 0 Disables input 15 as amp error status bit (Axes 5-8)
m = 1 Enables Input 15 as amp error status bit (Axes 5-8)
m = ? Returns the value of the amplifier error (Axes 5-8)

USAGE:

While Moving
In a Program
Command Line
Controller Usage

Yes
Yes
Yes

DEFAULTS:

Default Value AE0
Default Format --

**DMC-21x3 with AMP-20440 or DMC-2000, 2100, or 2200
with AMP-19540 with 7-IN jumper installed**

RELATED COMMANDS:

TA

Tell Amplifier

EXAMPLE:

AE1 Enables input 7 as the AMP-20440 amp error input

AG

FUNCTION: Amplifier Gain

DESCRIPTION:

The AG command sets the amplifier current/voltage gain for the AMP-205xx, and the current level for the AMP 206x0. 0 sets the lowest ratio or value while 2 sets the highest ratio for the 205xx, and 3 sets the highest current value for the 206x0. AG is stored in EEPROM by the BN command. The MT command must be issued prior to the AG command to set the proper range. The axis must be in the motor off state (MO) before new AG settings will take effect.

ARGUMENTS: AG n,n,n,n,n,n,n where

AMP 205x0:

- n = 0 0.4 A/V
- n = 1 0.7 A/V
- n = 2 1.0 A/V

AMP 20542:

- n = 0 0.1 A/V
- n = 1 0.25 A/V
- n = 2 0.5 A/V

AMP 206x0:

- n = 0 0.5 Amps/Phase
- n = 1 1.0 Amps/Phase
- n = 2 2.0 Amps/Phase
- n = 3 3.0 Amps/Phase

n = ? Returns the value of the amplifier gain

USAGE:

- While Moving No
- In a Program Yes
- Command Line Yes
- Controller Usage **DMC-21x3 with AMP-205xx or AMP 206x0**

DEFAULTS:

- Default Value 1, 1, 1, 1, 1, 1, 1, 1
- Default Format -

RELATED COMMANDS:

- TA Tell Amplifier
- AW Amplifier Bandwidth
- BS Brushless Setup

EXAMPLE:

- MO Set motor off
- AG 2,1 Sets the highest amplifier gain for A axis and medium gain for B axis on 205x0.
- AG 3,2 Sets the highest drive current of 3.0A for A axis and 2.0A gain for B axis on 206x0.
- SH Turn motor on.
- BN Save AG setting to EEPROM.

AU

FUNCTION: Set amplifier current loop

DESCRIPTION:

The AU command sets the amplifier current loop gain for the AMP-205xx. Current loop is available in one of two settings (0 is normal while 1 sets a higher current loop) Values stored in EEPROM by the BN command.

ARGUMENTS: AU n,n,n,n,n,n,n,n where

AMP-205x0:

n = 0 for normal current loop gain

n = 1 for higher current loop gain

AMP-20542:

n = 0 for normal current loop gain (Inverter)

n = 1 for higher current loop gain (Inverter)

n = 0.5 for normal current loop gain (Chopper)

n = 1.5 for higher current loop gain (Chopper)

USAGE:

While Moving	No
In a Program	Yes
Command Line	Yes
Controller Usage	DMC-21x3 with AMP-205xx

DEFAULTS:

Default Value	0,0,0,0,0,0,0
Default Format	-

RELATED COMMANDS:

TA	Tell Amplifier
AG	Amplifier Gain
BS	Brushless Setup
AW	Amplifier Bandwidth

EXAMPLE:

AU1,0	Sets X-axis to higher loop gain and Y-axis to normal loop gain
AUY=?	Query Y-axis current loop gain
:0	Y-axis normal current loop gain

AW

FUNCTION: Amplifier Bandwidth

DESCRIPTION:

The AW command accepts the drive voltage (volts) and motor inductance (millihenries) and uses the current loop gain setting (AU) as the default and then reports the calculated bandwidth. The user can check how the amplifier bandwidth is affected by changing the n parameter. If the axis is identified as connected to the AMP-205xx, the calculation uses the AMP-205xx transfer function. If the axis is connected to the AMP-204x0, then the algorithm uses the AMP-204x0 transfer function.

ARGUMENTS: AW_x = v, l, n where

x = Axis designator

v = Drive voltage in Volts

l = Motor inductance in millihenries

n = optional current loop gain setting (1 or 0)

USAGE:

While Moving	No
In a Program	Yes
Command Line	Yes
Controller Usage	DMC-21x3 with AMP-204x0 or AMP-205xx

DEFAULTS:

Default Value	0, 0, 0
Default Format	--

RELATED COMMANDS:

TA	Tell Amplifier
AG	Amplifier Gain
BS	Brushless Setup

EXAMPLE:

AWY=60,5,0	Sets a 60 volt drive, motor with 5 millihenries inductance and normal current loop gain
: 4525.732	Is the bandwidth in hertz

BR

FUNCTION: Brush Axis

DESCRIPTION:

The BR command is used in conjunction with an AMP-205x0 to enable which axis will be set as brush-type servo. The hall error bits are not set in the TA value when an axis is configured as brush-type. The hall inputs are available for general use via the QH command.

ARGUMENTS: BR n,n,n,n,n,n,n,n where
n = 0 Brushless servo axis
n = 1 Brush-type servo axis
n = ? Returns the value of the axis

USAGE:

While Moving Yes
In a Program Yes
Command Line Yes
Controller Usage

DEFAULTS:

Default Value 0, 0, 0, 0, 0, 0, 0, 0
Default Format --

DMC-21x3 with AMP-205xx

RELATED COMMANDS:

TA Tell Amplifier
QH Hall State

EXAMPLE:

BR1,0,0 Sets X-axis to brush-type, Y and Z to brushless

BS

FUNCTION: Brushless Setup

DESCRIPTION:

The command BS tests the wiring of a brushless motor. If Hall sensors are connected, this command also tests the wiring of the Hall sensors. This function can only be performed with one axis at a time.

This command returns status information regarding the setup of brushless motors. The following information will be returned by the controller:

1. The results of the hall sensor wiring test (If hall sensors are used).
2. Correct wiring of the brushless motor phases or how to change direction.

This command will turn the motor off when done and may be given when the motor is off.

Once the brushless motor is properly setup and the motor configuration has been saved in non-volatile memory, the BS command does not have to be re-issued. The configuration is saved by using the burn command, BN.

Note: In order to properly conduct the brushless setup, the motor must be allowed to move a minimum of one magnetic cycle in both directions.

ARGUMENTS: BSA= v, n where

v is a real number between 0 and 10. v represents the voltage level to be applied to each phase.

n is a positive integer between 100 or 1000. n represents the duration in milliseconds that voltage should be applied to the motor phases.

USAGE:

While Moving
In a Program
Command Line
Controller Usage

No
Yes
Yes

DEFAULTS:

Default Value of n 0
Default Value of n 200

ALL CONTROLLERS / DMC 21x3 with AMP-205xx

EXAMPLES:

BSC = 2,900 Apply set up test to C axis with 2 volts for 900 millisecond on each step.

Note 1: When using Galil Windows software, the timeout must be set to a minimum of 10 seconds (timeout = 10000) when executing the BS command. This allows the software to retrieve all messages returned from the controller.

Note 2: For a DMC-21x3 with an attached AMP-205x0, the BS command performs an algorithm that verifies the correct motor phase wiring. If incorrect, the command will recommend the correct motor phase wiring.

Example: BSY=
: Wire A to terminal B, wire B to terminal A

CN

FUNCTION: Configure

DESCRIPTION:

The CN command configures the polarity of the limit switches, home switches, latch inputs, the selective abort function, and the program status after a hard abort.

ARGUMENTS: CN m,n,o,p,q where
 m,n,o are integers with values 1 or -1.
 p,q are 0 or 1.

m =	1	Limit switches active high
	-1	Limit switches active low
n =	1	Home switch configured to drive motor in forward direction when input is high. See HM and FE commands.
	-1	Home switch configured to drive motor in reverse direction when input is high. See HM and FE commands
o =	1	Latch input is active high
	-1	Latch input is active low
p =	1	Configures inputs 5,6,7,8,13,14,15,16 as selective abort inputs for axes A,B,C,D,E,F,G,and H respectively
	0	Inputs 5,6,7,8,13,14,15,16 are configured as general use inputs
q =	1	Abort input will not terminate program execution
	0	Abort input will terminate program execution

USAGE:

While Moving Yes
 In a Program Yes
 Command Line Yes
 Controller Usage **ALL CONTROLLERS**

DEFAULTS:

Default Value -1,-1,-1,0,0
 Default Format 2.0

OPERAND USAGE:

_CN0 Contains the limit switch configuration
 _CN1 Contains the home switch configuration
 _CN2 Contains the latch input configuration
 _CN3 Contains the state of the selective abort function (1 enabled, 0 disabled)
 _CN4 Contains the configuration of program execution upon hard abort input

EXAMPLES:

CN 1,1 Sets limit and home switches to active high
 CN, -1 Sets input latch active low

CO

FUNCTION: Configure Extended I/O

DESCRIPTION:

The CO command configures the extended I/O.

The 64 extended I/O points of the controller can be configured in banks of 8. The extended I/O is denoted as bits 17-80 and banks 2-9.

ARGUMENTS: CO n where

n is a decimal value which represents a binary number. Each bit of the binary number represents one bank of extended I/O. When set to 1, the corresponding bank is configured as an output.

The least significant bit represents bank 2 and the most significant bit represents bank 9. The decimal value can be calculated by the following formula:

$$n = n_2 + 2*n_3 + 4*n_4 + 8*n_5 + 16*n_6 + 32*n_7 + 64*n_8 + 128*n_9$$

where n_x represents the bank.

To configure a bank as an output bank, substitute a one into that n_x in the formula. If the n_x value is a zero, then the bank of 8 I/O points will be configured as an input. For example, if banks 3 and 4 are to be configured outputs, CO 6 is issued. Use MG_CO to verify the daughter board is capable of the desired configuration.

USAGE:

While Moving	Yes
In a Program	Yes
Command Line	Yes
Controller Usage	

DEFAULTS:

Default Value	-
Default Format	-

ALL CONTROLLERS WITH I/O DAUGHTER BOARD

OPERAND USAGE:

_CO returns the extended I/O configuration value

EXAMPLES:

CO 255	Configure all points as outputs
CO 0	Configure all points as inputs
CO 1	Configures bank 1 to outputs on extended I/O

LC

FUNCTION: Low Current Stepper Mode

DESCRIPTION:

Causes the amp enable line for the specified axes to toggle (disabling the stepper drives) when the respective axes stop (profiler holding position). Each axis is handled individually with either full, 25%, or no current at rest. This will reduce current consumption, but there will be low or no holding torque at rest. The MT command must be issued prior to the LC command.

ARGUMENTS: LC n,n,n,n,n,n,n,n where

- n = 0 Normal (stepper drive always on)
- n = 1 Low current stepper mode (25% holding current)
- n = 2 No current stepper mode (0% holding current) (AMP 206x0 only)
- n = ? Returns whether the axis is in low current stepper mode

Low Current Setting Current: LC n,n,n,n,n,n,n,n			
	AMP 20240	AMP 206x0	External Drive
n = 0	100%	100%	100%
n = 1	25% *	25%	0%
n = 2	N/A	0%	0%

* LC function for SDM
20240 requires jumper
installation at JP1.

USAGE:

While Moving
In a Program
Command Line
Controller Usage

DEFAULTS:

Yes Default Value 0
Yes Default Format 1.0

ALL CONTROLLERS

EXAMPLES:

MTZ=2 Specify stepper mode for the z axis
LCZ=1 Specify low current mode for the z axis

TA

FUNCTION: Tell Amplifier Error Status

DESCRIPTION:

The command transmits the amplifier error status. The value is decimal and represents an 8 bit value.

TA0		TA1		TA2		TA3	
Bit #	STATUS	Bit #	STATUS	Bit #	STATUS	Bit #	STATUS
Bit 7	Under Voltage (E-H Axes)	Bit 7	Hall Error H Axis	Bit 7	Peak Current H-Axis	Bit 7	0
Bit 6	Over Temperature (E-H Axes)	Bit 6	Hall Error G Axis	Bit 6	Peak Current G-Axis	Bit 6	0
Bit 5	Over Voltage (E-H Axes)	Bit 5	Hall Error F Axis	Bit 5	Peak Current F-Axis	Bit 5	0
Bit 4	Over Current * (E-H Axes)	Bit 4	Hall Error E Axis	Bit 4	Peak Current E-Axis	Bit 4	0
Bit 3	Under Voltage (A-D Axes)	Bit 3	Hall Error D Axis	Bit 3	Peak Current D-Axis	Bit 3	0
Bit 2	Over Temperature (A-D Axes)	Bit 2	Hall Error C Axis	Bit 2	Peak Current C-Axis	Bit 2	0
Bit 1	Over Voltage (A-D Axes)	Bit 1	Hall Error B Axis	Bit 1	Peak Current B-Axis	Bit 1	ELO Active (E-H Axes)
Bit 0	Over Current * (A-D Axes)	Bit 0	Hall Error A Axis	Bit 0	Peak Current A-Axis	Bit 0	ELO Active (A-D Axes)

ARGUMENTS: TA n returns the amplifier error status where n is 0,1,2, or 3

USAGE:

While Moving Yes
 In a Program Yes
 Command Line Yes
 Controller Usage **DMC-21x3 with AMP-204x0, AMP-205xx, or AMP 206x0**

DEFAULTS:

Default Value -
 Default Format 1.0

OPERAND USAGE:

_TAn Contains the Amplifier error status

RELATED COMMANDS:

BR Brush Axis Configuration
 QH Hall State

EXAMPLE:

TA1
 :5 Hall Error for Axis A and C

*When used with the AMP-20440, only bit 0 of TA0 will be set for all axes A-H.

TK

FUNCTION: Peak Torque Limit

DESCRIPTION:

The TK command sets the peak torque limit on the motor command output and TL sets the continuous torque limit. When the average torque is below TL, the motor command signal can go up to the TK (Peak Torque) for a short amount of time. If TK is set lower than TL, then TL is the maximum command output under all circumstances.

ARGUMENTS: TK n,n,n,n,n,n,n

n is an unsigned number in the range of 0 to 9.99 volts

n=0 disables the peak torque limit

n=? returns the value of the peak torque limit for the specified axis.

USAGE:

While Moving	Yes	Default Value	0,0,0,0,0,0,0
In a Program	Yes	Default Format	1.0
Command Line	Yes		
Controller Usage	ALL CONTROLLERS		

OPERAND USAGE:

_TKn contains the value of the peak torque limit for the specified axis.

RELATED COMMANDS:

AG	Amplifier Gain
TL	Torque Limit

EXAMPLES:

TLA=7 Limit A-axis to a 7 volt average torque output

TKA=9.99 Limit A-axis to a 9.99 volt peak torque output

TL (Binary 8a)

FUNCTION: Continuous Torque Limit

DESCRIPTION:

The TL command sets the continuous limit on the motor command output. For example, TL5 limits the motor command output to 5 volts. The maximum output of the motor command is 9.9982 volts. If the amplifier gain is set to AG2 on the AMP-205x0, then the TL will be automatically set to 6.5. The TK value will remain as set, but can be set as high as 9.9982 volts.

ARGUMENTS: TL n,n,n,n,n,n,n,n or TLA=n where

n is an unsigned numbers in the range 0 to 9.9982 volts with resolution of 0.0003 volts

n = ? Returns the value of the torque limit for the specified axis.

USAGE:

While Moving	Yes
In a Program	Yes
Command Line	Yes
Controller Usage	ALL CONTROLLERS

DEFAULTS:

Default Value	9.9982
Default Format	1.0

OPERAND USAGE:

_TLn contains the value of the torque limit for the specified axis.

RELATED COMMANDS:

AG	Amplifier Gain
TK	Peak Torque Limit

EXAMPLES:

TL 1,5,9,7.5	Limit A-axis to 1volt Limit B-axis to 5 volts Limit C-axis to 9 volts Limit D-axis to 7.5 volts
TL ?,?,?,?	Return limits
1.0000,5.0000,9.0000, 7.5000	
TL ?	Return A-axis limit
1.0000	